

A stylized paper airplane icon in shades of blue and grey is positioned above a dashed grey line that forms a wave-like path across the middle of the cover.

**CIVIL AVIATION GUIDANCE MATERIAL – 1403**

# **APRON MARKINGS AND SIGNS**

**CIVIL AVIATION AUTHORITY OF MALAYSIA**

**ISSUE 02**  
REVISION 00 – 4<sup>TH</sup> FEBRUARY 2025

**INTENTIONALLY LEFT BLANK**

## Introduction

This Civil Aviation Guidance Material 1403 (CAGM – 1403) is issued by the Civil Aviation Authority of Malaysia (CAAM) to provide guidance for the Apron Markings and Signs, pursuant to Civil Aviation Directives 14 Vol. I – Aerodrome Design and Operations (CAD 14 Vol. I – Aerodrome Design and Operations).

Organisations may use these guidelines to ensure compliance with the respective provisions of the relevant CADs issued. Notwithstanding the Regulation 65 of the Civil Aviation (Aerodrome Operations) Regulations 2016 (CA (AO) R 2016), when the CAGMs issued by the CAAM are complied with, the related requirements of the CADs may be deemed as being satisfied and further demonstration of compliance may not be required.



**(Dato' Captain Norazman Bin Mahmud)**  
Chief Executive Officer  
Civil Aviation Authority of Malaysia

## Civil Aviation Guidance Material components and Editorial practices

This Civil Aviation Guidance Material is made up of the following components and are defined as follows:

**Standards:** Usually preceded by words such as “*shall*” or “*must*”, are any specification for physical characteristics, configuration, performance, personnel or procedure, where uniform application is necessary for the safety or regularity of air navigation and to which Operators must conform. In the event of impossibility of compliance, notification to the CAAM is compulsory.

**Recommended Practices:** Usually preceded by the words such as “*should*” or “*may*”, are any specification for physical characteristics, configuration, performance, personnel or procedure, where the uniform application is desirable in the interest of safety, regularity or efficiency of air navigation, and to which Operators will endeavour to conform.

**Appendices:** Material grouped separately for convenience, but forms part of the Standards and Recommended Practices stipulated by the CAAM.

**Definitions:** Terms used in the Standards and Recommended Practices which are not self-explanatory in that they do not have accepted dictionary meanings. A definition does not have an independent status but is an essential part of each Standard and Recommended Practice in which the term is used, since a change in the meaning of the term would affect the specification.

**Tables and Figures:** These add to or illustrate a Standard or Recommended Practice, and which are referred to therein, form part of the associated Standard or Recommended Practice and have the same status.

**Notes:** Included in the text, where appropriate, Notes give factual information or references bearing on the Standards or Recommended Practices in question but not constituting part of the Standards or Recommended Practices;

**Attachments:** Material supplementary to the Standards and Recommended Practices or included as a guide to their application.

It is to be noted that some Standards in this Civil Aviation Guidance Material incorporates, by reference, other specifications having the status of Recommended Practices. In such cases, the text of the Recommended Practice becomes part of the Standard.

The units of measurement used in this document are in accordance with the International System of Units (SI) as specified in CAD 5. Where CAD 5 permits the use of non-SI alternative units, these are shown in parentheses following the basic units. Where two sets of units are quoted it must not be assumed that the pairs of values are equal and interchangeable. It may, however, be inferred that an equivalent level of safety is achieved when either set of units is used exclusively.

Any reference to a portion of this document, which is identified by a number and/or title, includes all subdivisions of that portion.

Throughout this Civil Aviation Guidance Material, the use of the male gender should be understood to include male and female persons.





**INTENTIONALLY LEFT BLANK**



## Summary of Changes

ISS/REV no.	Item No.	Revision Details
ISS02/REV00	Introduction	Editorial Changes
	Para 1.1.3	Amendment
	Para 1.1.4	Amendment
	Para 1.2.1	Amendment
	Para 2.1.7	Amendment
	Para 4.5	Amendment
	Para 4.9	Amendment
	Para 4.10	Amendment
	Para 4.11	Amendment
	Para 5.2	Amendment
	Para 5.2.1	Amendment, additional information added
	Para 5.3.1	Amendment
	Para 5.3.2	Amendment
	Para 5.3.3	Amendment
	Para 5.4	Amendment
	Para 5.4.1	Amendment
	Para 5.4.2	Amendment
	Para 5.4.3	Amendment
	Para 8.2	Amendment
	Para 8.3	Additional information added
	Para 8.4	Additional information added
	Para 8.5	Additional information added
	Para 12.1	Amendment
	Para 12.3	Amendment
	Para 13.1	Amendment
	Para 14.3	Amendment
	Para 16.3	Amendment
	Para 18.1	Amendment
	Para 21.1	Amendment
	Para 21.3	Amendment
	Para 21.5	Amendment
	Para 21.6	Amendment
	Para 21.7	Amendment
	Para 21.8	Amendment



**INTENTIONALLY LEFT BLANK**





## Table of Contents

<b>1</b>	<b>GENERAL</b> .....	<b>1-1</b>
<b>2</b>	<b>MARKINGS</b> .....	<b>2-1</b>
<b>3</b>	<b>TYPES OF AIRCRAFT STANDS</b> .....	<b>3-1</b>
<b>4</b>	<b>PIPO MARKINGS</b> .....	<b>4-1</b>
<b>5</b>	<b>PIPB MARKINGS</b> .....	<b>5-1</b>
<b>6</b>	<b>TAXI SIDE STRIPE MARKING ON APRON EDGE</b> .....	<b>6-1</b>
<b>7</b>	<b>APRON SAFETY LINE MARKING</b> .....	<b>7-1</b>
<b>8</b>	<b>SECONDARY MARKINGS FOR LEAD-IN, TURNING, LEAD-OUT, TURN BAR, ALIGNMENT BAR AND STOP LINE</b> 8-1	
<b>9</b>	<b>STOP LINE MARKING FOR NO PASSENGER BOARDING BRIDGE (PBB) OPERATIONS</b> .....	<b>9-1</b>
<b>10</b>	<b>AIRCRAFT ENGINE START-UP POSITION LINE MARKING</b> .....	<b>10-1</b>
<b>11</b>	<b>NO PARKING AREA MARKING</b> .....	<b>11-1</b>
<b>12</b>	<b>PBB WHEEL POSITION</b> .....	<b>12-1</b>
<b>13</b>	<b>FUEL HYDRANT MARKING</b> .....	<b>13-1</b>
<b>14</b>	<b>TRACTOR PUSHBACK LINE AND PUSHBACK LIMIT LINE MARKING</b> .....	<b>14-1</b>
<b>15</b>	<b>VEHICLE AND EQUIPMENT PARKING AREA</b> .....	<b>15-1</b>
<b>16</b>	<b>NOSE TIP CLEARANCE LINES</b> .....	<b>16-1</b>
<b>17</b>	<b>WING TIP CLEARANCE LINES</b> .....	<b>17-1</b>
<b>18</b>	<b>DISTANCE FROM UPPERMOST STOP LINE MARKING TO THE SERVICE ROAD/ PASSENGER PATH/ BUILDING/ OBJECT</b> .....	<b>18-1</b>
<b>19</b>	<b>PASSENGER PATH LINES ON APRON</b> .....	<b>19-1</b>
<b>20</b>	<b>TAXIWAY/AIRCRAFT STAND TAXILANE CROSSING MARKING</b> .....	<b>20-1</b>
<b>21</b>	<b>GENERAL REQUIREMENTS FOR AIRCRAFT STAND IDENTIFICATION SIGNS</b> .....	<b>21-1</b>
<b>22</b>	<b>AIRCRAFT TYPE DESIGNATOR</b> .....	<b>22-1</b>
<b>23</b>	<b>APPENDICES</b> .....	<b>23-1</b>
23.1	APPENDIX 1. MANDATORY INSTRUCTION MARKINGS AND INFORMATION MARKINGS .....	23-1
23.2	APPENDIX 2. HUMAN FIGURE DIMENSION FOR PASSENGER PATH LINE.....	23-5



**INTENTIONALLY LEFT BLANK**

# 1 General

## 1.1 Introduction

1.1.1 This Document provides simple tabulated measurements and graphical explanation in general terms, the purpose and pattern of markings to be used at aerodrome in Malaysia.

1.1.2 Existing markings and signs will remain until such time new development, replacement or repainting is needed.

1.1.3 This document has been written in general terms. Specific advice could be obtained from the Authority at:

**CIVIL AVIATION AUTHORITY OF MALAYSIA**

Air Navigation Services & Aerodrome Division

Level 1 Block Podium B

No. 27 Persiaran Perdana

Precinct 4,

62618 PUTRAJAYA

Phone: 03-88714000

Fax: 03-88714335

1.1.4 This document outlines the type, location, and characteristics of apron markings and signs to be implemented at aerodromes. Compliance by aerodrome operators is essential to ensure the safety of aircraft operations. To achieve this, the highest standards in the design and provision of apron markings and signs must be maintained. The effectiveness of these facilities depends not only on their proper installation but also on their ongoing availability and visibility, which are directly influenced by the quality of maintenance.

## 1.2 Applicability

1.2.1 The specification in this Document should apply to aerodromes open to public transport aircraft.

## 1.3 Authority

1.3.1 The Authority referred to this Document is the Chief Executive Officer of Civil Aviation Authority of Malaysia.

## 1.4 Aerodrome Reference Code

1.4.1 The intent of the reference code is to provide a simple method for interrelating the numerous specifications concerning the characteristics of aerodromes so as to provide a series of aerodrome facilities that are suitable for the aeroplanes that are intended to operate at the aerodrome. The code is not intended to be used for determining runway length or pavement strength requirements. The code is

composed of two elements which are related to the aeroplane performance characteristics and dimensions.

1.4.2 Element 1 is a number based on the aeroplane reference field length.

1.4.3 Element 2 is a letter based on the aeroplane wingspan.

**Table 1-1. Aerodrome Reference Code**

Code element 1		Code element 2	
Code number	Aeroplane reference field length	Code Letter	Wingspan
(1)	(2)	(3)	(4)
1	Less than 800m	A	Up to but not including 15m
2	800m up to but not including 1200m	B	15m up to but not including 24m
3	1200m up to but not including 1800m	C	24m up to but not including 36m
4	1800m and over	D	36m up to but not including 52m
		E	52m up to but not including 65m
		F	65m up to but not including 80m

## 1.5 Apron and Aircraft Stand

1.5.1 Aprons shall be provided where necessary to permit the on- and off-loading of passengers, cargo or mail as well as the servicing of aircraft without interfering with the aerodrome traffic.

1.5.2 The apron is generally paved but may occasionally be unpaved; for example, in some instances, a turf parking apron may be adequate for small aircraft.

1.5.3 Aircraft stand markings shall be provided for designated parking position on a paved apron.

**1.6 Clearance Distances on Aircraft Stands**

1.6.1 An aircraft stand shall provide the following minimum clearances between an aircraft entering or exiting the stand and any adjacent building, aircraft on another stand and other objects.

**Table 1-2. Clearance Requirement**

<i>Code Letter</i>	<i>Clearance (m)</i>
A	3.0
B	3.0
C	4.5
D	7.5
E	7.5
F	7.5

1.6.2 When special circumstances so warrant, these clearances may be reduced at a nose- in aircraft stand, where the code letter is D, E or F:

- a) between the terminal, including any fixed passenger bridge, and the nose of an aircraft; and
- b) over any portion of the stand provided with azimuth guidance by a visual docking guidance system.

**1.7 Apron Taxiways and Aircraft Stand Taxilane**

1.7.1 Taxiway, other than aircraft stand taxilane (Apron taxiways) and aircraft stand taxilane shall provide the following minimum separation distance between the centre line of these taxiways an aircraft at the stands:

**Table 1-3. Minimum Separation Distances**

<i>Code Letter</i>	<i>Taxiway, other than aircraft stand taxilane, centre line to object (m)</i>	<i>Aircraft stand taxilane centre line to object (m)</i>	<i>Aircraft stand taxilane centre line to aircraft stand taxilane centre line (m)</i>
A	15.5	12	19.5
B	20	16.5	28.5
C	26	22.5	40.5
D	37	33.5	59.5
E	43.5	40	72.5
F	51	47.5	87.5



**INTENTIONALLY LEFT BLANK**

## 2 Markings

### 2.1 General Requirements for Apron Marking

- 2.1.1 Aircraft stand markings shall include such elements as stand identification, lead-in line, turning line, stop line and lead-out line, as are required by the parking configuration and to complement other parking aids. While for PIPO operations, there are additional markings which are turn bar and alignment bar.
- 2.1.2 An aircraft stand identification (letter and/or number) shall be included in the lead-in line a short distance after the beginning of the lead-in line.
- 2.1.3 Where two sets of aircraft stand markings are superimposed on each other in order to permit more flexible use of the apron and it is difficult to identify which stand marking shall be followed, or safety would be impaired if the wrong marking was followed, then identification of the aircraft for which each set of markings is intended shall be added to the stand identification.
- 2.1.4 Lead-in, turning and lead-out lines shall normally be continuous in length and have a width of not less than 15 cm. Where one or more sets of stand markings are superimposed on a stand marking, the lines shall be continuous for the most demanding aircraft and broken for other aircraft.
- 2.1.5 The curved portions of lead-in, turning and lead-out lines shall have radius appropriate to the most demanding aircraft type for which the markings are intended. The radius shall be referred from the manuals issued by the aircraft manufacturers for airport planning purposes.
- 2.1.6 Where it is intended that an aircraft proceed in one direction only, arrows pointing in the direction to be followed shall be added as part of the lead in and lead-out lines.
- 2.1.7 Aircraft Stand Identification Marking for Power-in Power-out (PIPO) aircraft stand should face to the direction of pilot while for Power-in Push-back (PIPB) aircraft stand should face to the direction of marshaller.
- 2.1.8 A turn bar shall be located at right angles to the lead-in line, abeam the left pilot position at the point of initiation of any intended turn. It shall have a length and width of not less than 6 m and 15 cm, respectively, and include an arrowhead to indicate the direction of turn.
- 2.1.9 If more than one turn bar and/or stop line is required, they shall be coded.
- 2.1.10 An alignment bar shall be placed so as to be coincident with the extended centre line of the aircraft in the specified parking position and visible to the pilot during the final part of the parking manoeuvre. It shall have a width of not less than 15 cm.

- 2.1.11 A stop line shall be located at right angles to the alignment bar, abeam the left pilot position at the intended point of stop. It shall have a length and width of not less than 6 m and 15 cm, respectively.
- 2.1.12 Where there is insufficient contrast between the marking and the pavement surface, the aircraft stand markings and other apron markings shall include an appropriate border in contrasting colour on both sides as follows: -
- a) Black border – for yellow and white markings on light coloured pavement
  - b) White border – for red markings on dark coloured pavement

## 2.2 Aircraft Stand Markings

- 2.2.1 Aircraft stand markings shall be yellow.
- 2.2.2 There are two types of aircraft stand markings:
- a) Power-in Power-out (PIPO)
  - b) Power-in Push-back (PIPB)



### 3 Types of Aircraft Stands

#### 3.1 Power-In Power-Out (PIPO)

3.1.1 This term denotes the procedure whereby an aircraft enters and leaves the aircraft stand under its own power, that is, without recourse to a tractor for any part of the manoeuvre.

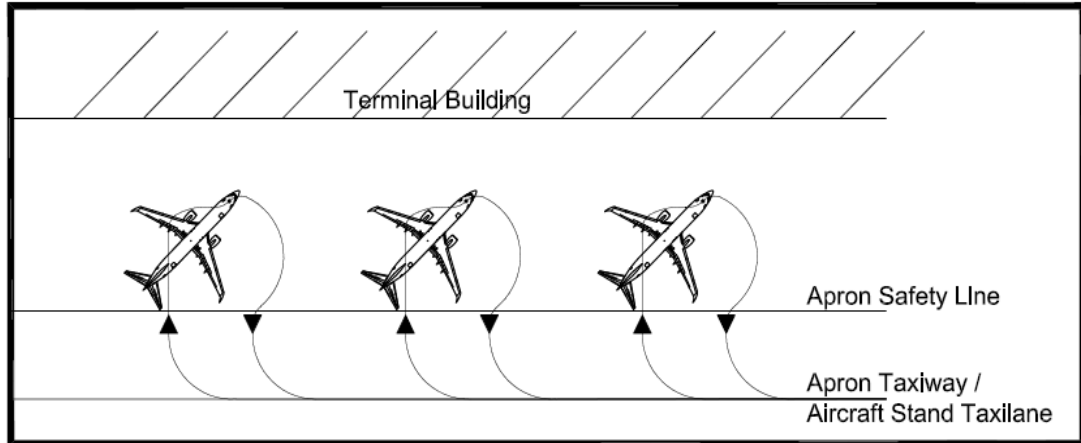

a) Angle nose-in parking

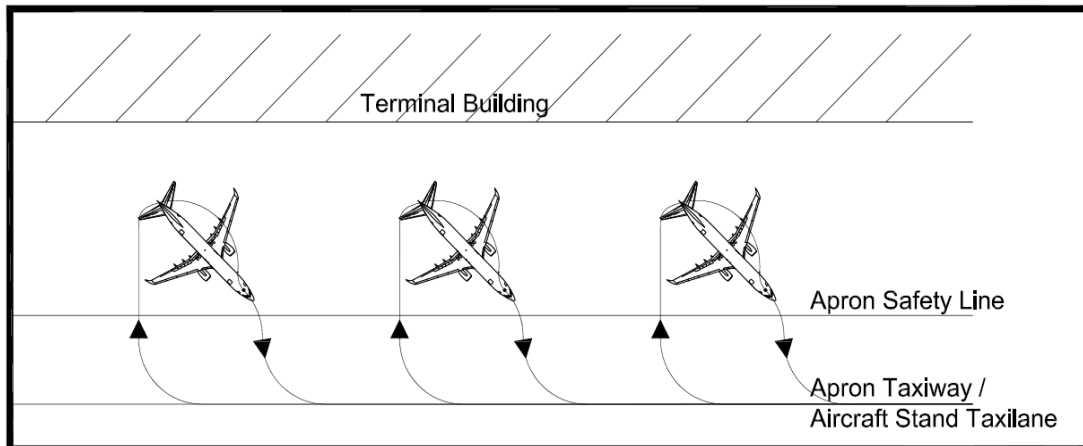

b) Angle nose-out parking

Figure 3-1. Examples of PIPO parking configuration

#### 3.2 Power-In Push-Back (PIPB)

*Note. – This term applies to any method of ingress and egress that requires the use of a tractor and tow bar. The most common procedure is the taxi-in, push-out method. Use of tractors allows a much closer spacing of aircraft stands, reducing both the apron and terminal space required to accommodate a high volume of terminal aircraft parking.*

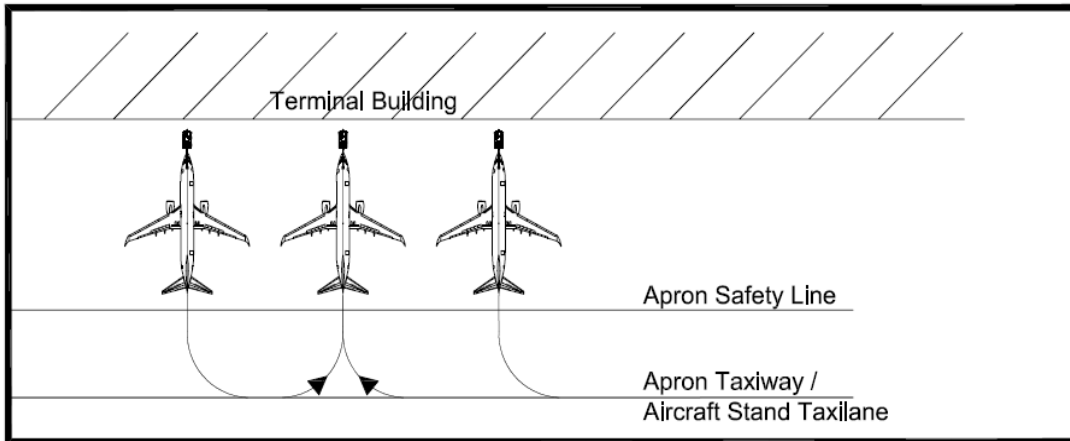

**Figure 3-2. Example of PIPB parking configuration**

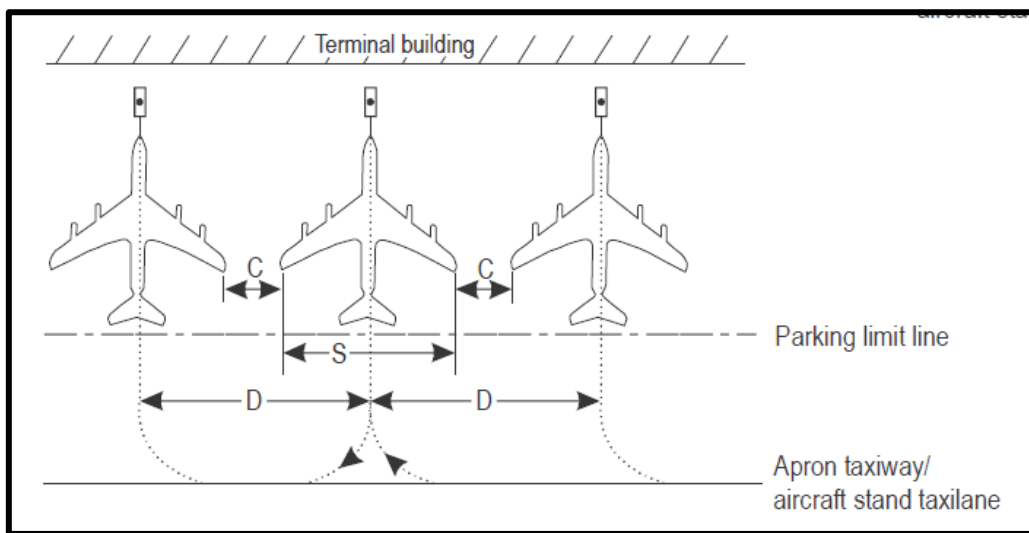

**Figure 3-3. Stand spacing**

*Stand spacing.* General formulas have been developed in a number of cases to calculate the required distance between aircraft stands. The simplest case is for aircraft that taxi in perpendicular to the terminal building and push out straight back. As shown in Figure 3-4 d), the minimum stand spacing (D) equals the wing span (S) plus the required clearance (C).

## 4 PIPO Markings

4.1 PIPO Markings shall consist of:

- a) Lead-in line
- b) Turning line
- c) Lead-out line
- d) Turn bar
- e) Stop line
- f) Alignment bar
- g) Arrows
- h) Aircraft Stand Identification

4.2 If more than one turn bar line is required, they shall be coded.

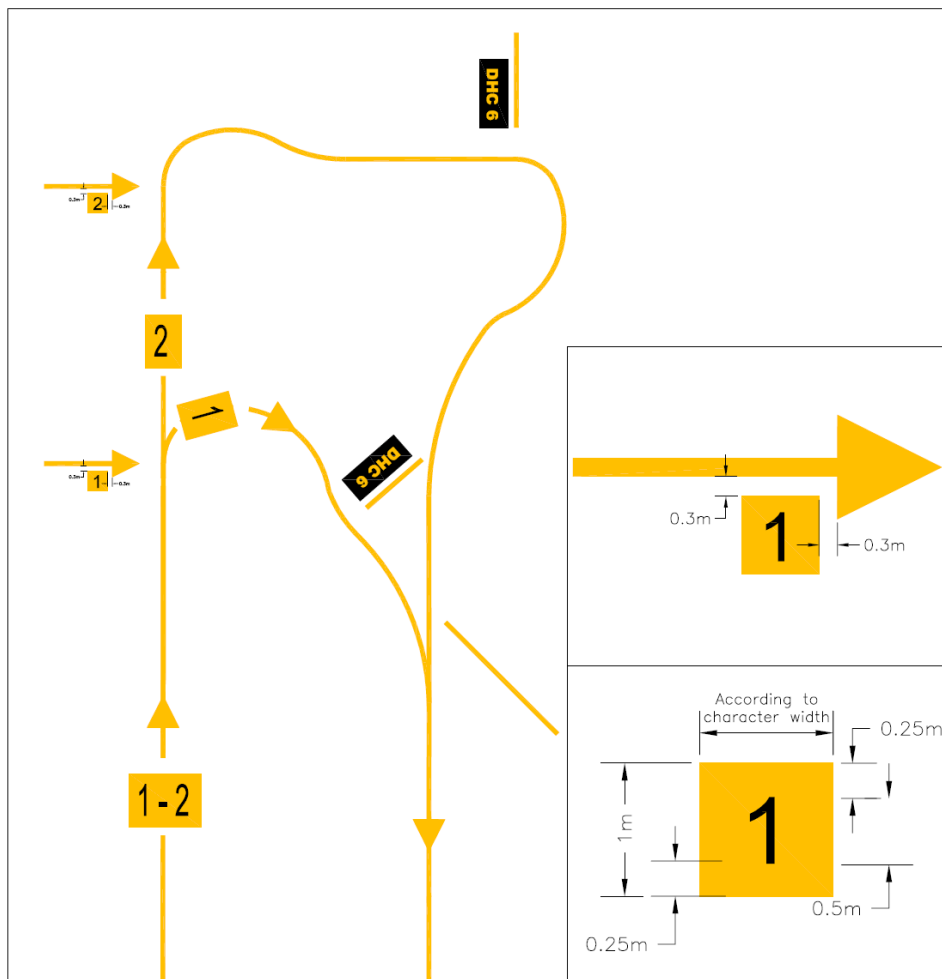

Figure 4-1. Example of Turn Bar with Coded

- 4.3 An alignment bar shall be placed so as to be coincident with the extended centre line of the aircraft in the specified parking position and visible to the pilot during the final part of the parking manoeuvre. It shall have a width of not less than 15 cm.
- 4.4 A stop line shall be located at right angles to the alignment bar, abeam the left pilot position at the intended point of stop. It shall have a length and width of not less than 6 m and 15 cm, respectively.
- 4.5 A turn bar shall be located at right angles to the lead-in line, abeam the left pilot position at the point of initiation of any intended turn. It shall have a length and width of not less than 6 m and 15 cm, respectively, and include an arrowhead to indicate the direction of turn.

*Note 1. – Where there is space constraint, the position of the alignment bar and stop line may be located abeam the right pilot position subject to approval by CAAM Air Navigation Services & Aerodrome.*

*Note 2. – Where there is space constraint, the length of alignment bar, stop line and turn bar marking can be reduced subject to approval by CAAM Air Navigation Services & Aerodrome.*

4.6 Lead-in Line Marking

- a) Purpose – To allow an aircraft to taxi under its own power or to be towed whilst maintaining the necessary clearances from obstacles.
- b) Characteristic – Lead-in line marking shall normally be continuous in length and have a width of not less than 0.15 m.

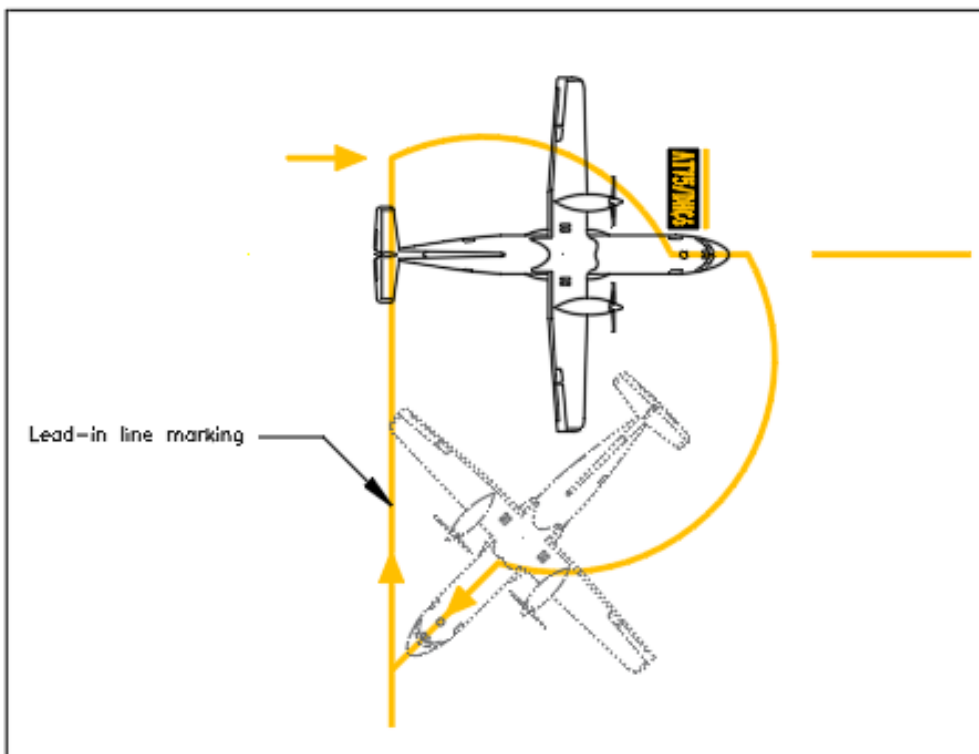

**Figure 4-2. Example of Lead-in Line Marking**



**Figure 4-3. Lead-in Line Marking**

4.7 Turning Line Marking

- a) Purpose – Where the aircraft is required to make a turn on the stand prior to stopping or after “break away”, a turning line should be needed for the aircraft to follow. The primary purpose of this line is to limit the turning of aircraft within the designated area so as to keep aircraft clear of obstacles and to aid in accurate positioning of the aircraft.
- b) Characteristic – Turning line marking shall normally be continuous in length and have a width of not less than 0.15 m.

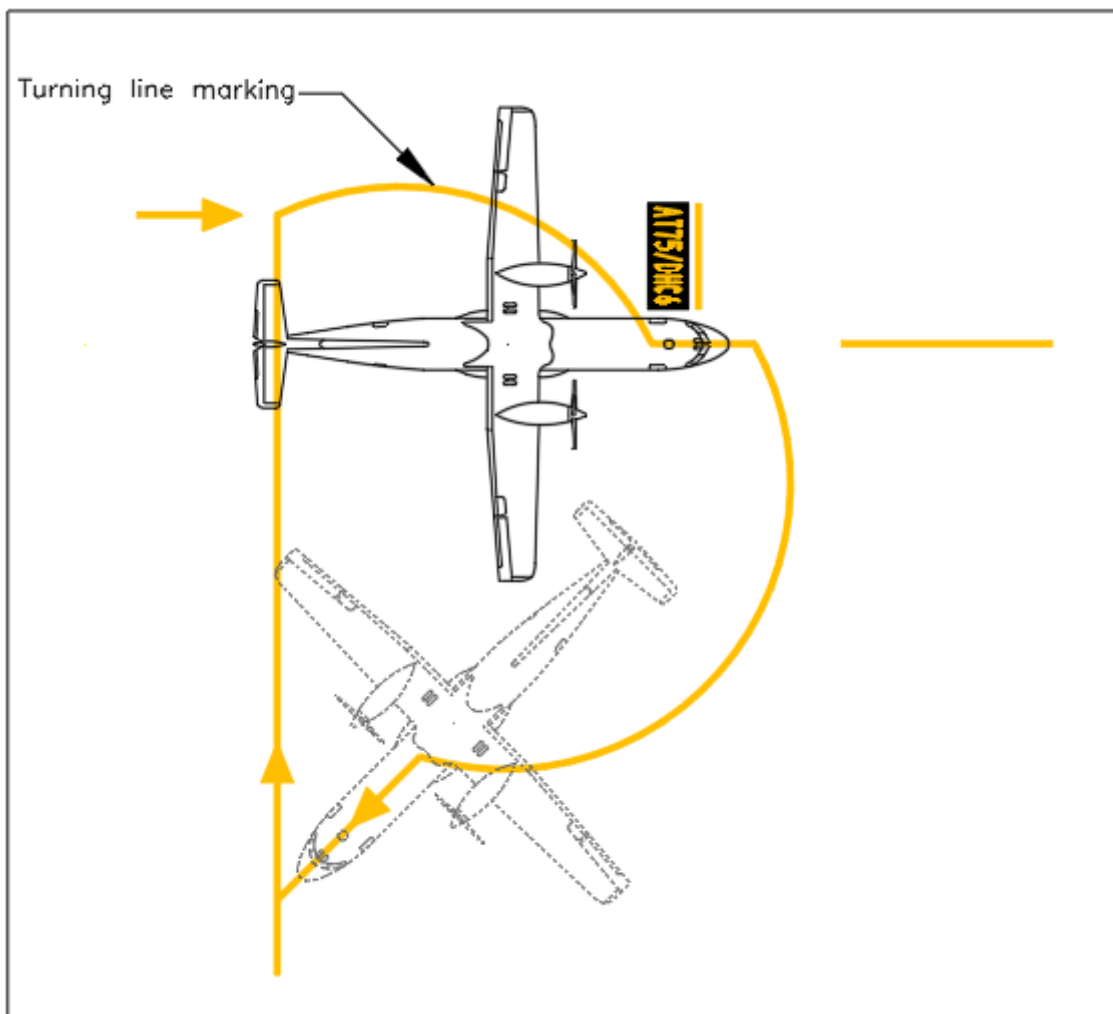

**Figure 4-4. Example of Turning Line Marking**



**Figure 4-5. Turning Line Marking**

4.8 Lead-out Line Marking

- a) Purpose – This line provides guidance from aircraft stand to taxiway and ensure that the prescribed clearance from other aircraft and obstacles is maintained.
- b) Characteristic – Lead-out line marking shall normally be continuous in length and have a width of not less than 0.15 m.

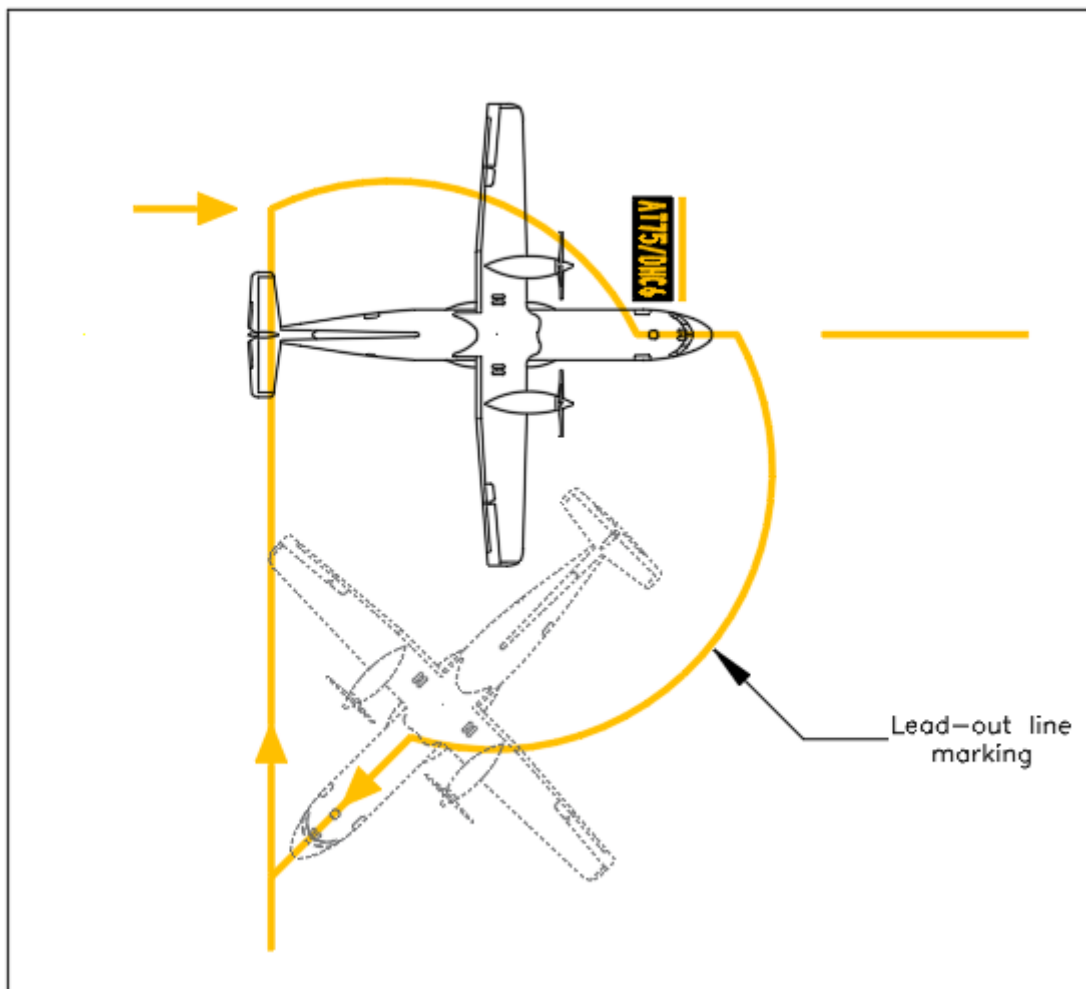

**Figure 4-6. Example of Lead-out Line Marking**

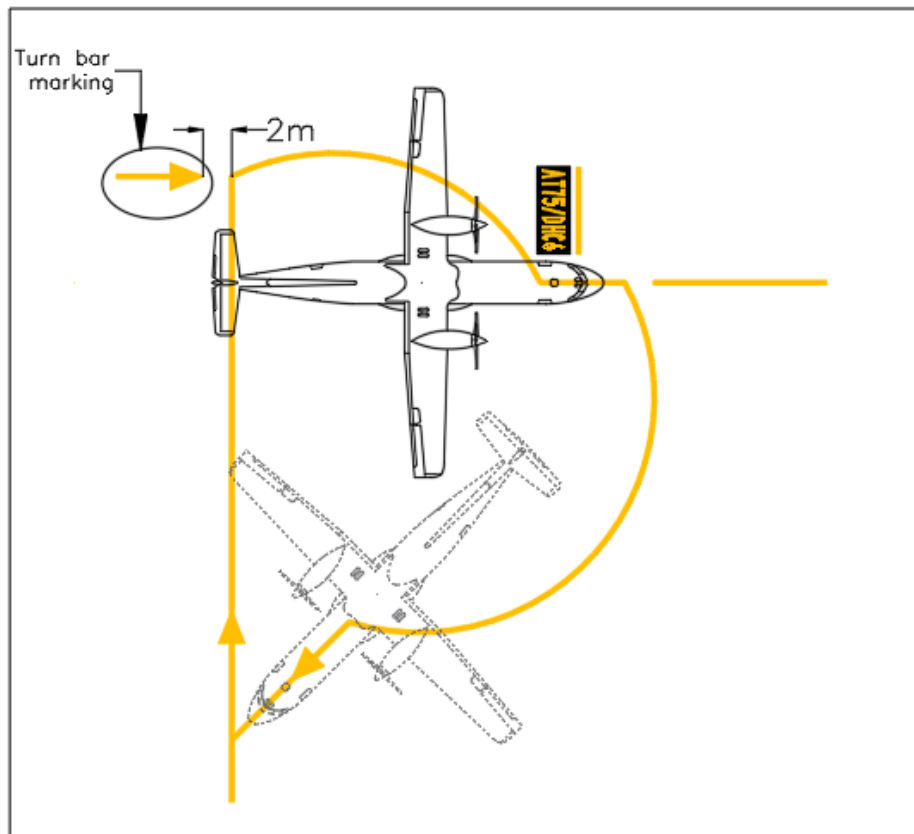

**Figure 4-7. Lead-out Line Marking**

4.9 Turn Bar Marking

- a) Purpose – This marking indicates the point at which aircraft begin a turn.
- b) Location – A turn bar shall be located at right angle to the lead-in line, abeam the left pilot position at the point of initiation of any intended turn.
- c) Characteristics – It shall have a length and width of not less than 6 m and 0.15 m respectively.

*Note. – Where there is space constraint, the length of turn bar marking can be reduced subject to approval by CAAM Air Navigation Services & Aerodrome.*



**Figure 4-8. Example of Turn Bar Marking**

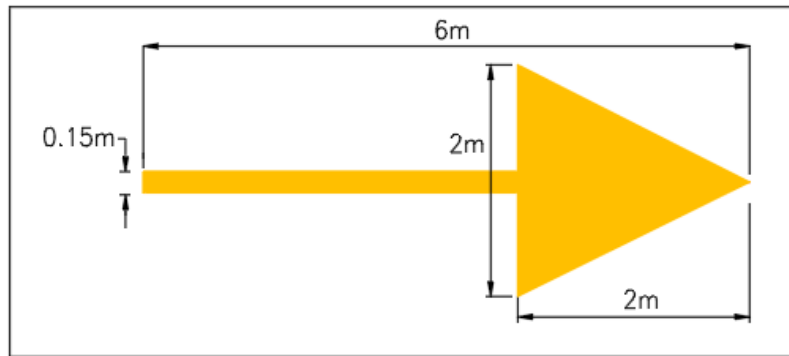

**Figure 4-9. Turn Bar Marking**

#### 4.10 Stop Line Marking

- Purpose – This marking indicates the point at which aircraft need to stop.
- Location – A stop line shall be located at right angle to the alignment bar, abeam the left pilot position at the intended point of stop.
- Characteristics – It shall have a length and width of not less than 6 m and 0.15 m respectively.

*Note. – Where space is limited, the length of stop line can be reduced subject to approval by CAAM Air Navigation Services & Aerodrome.*



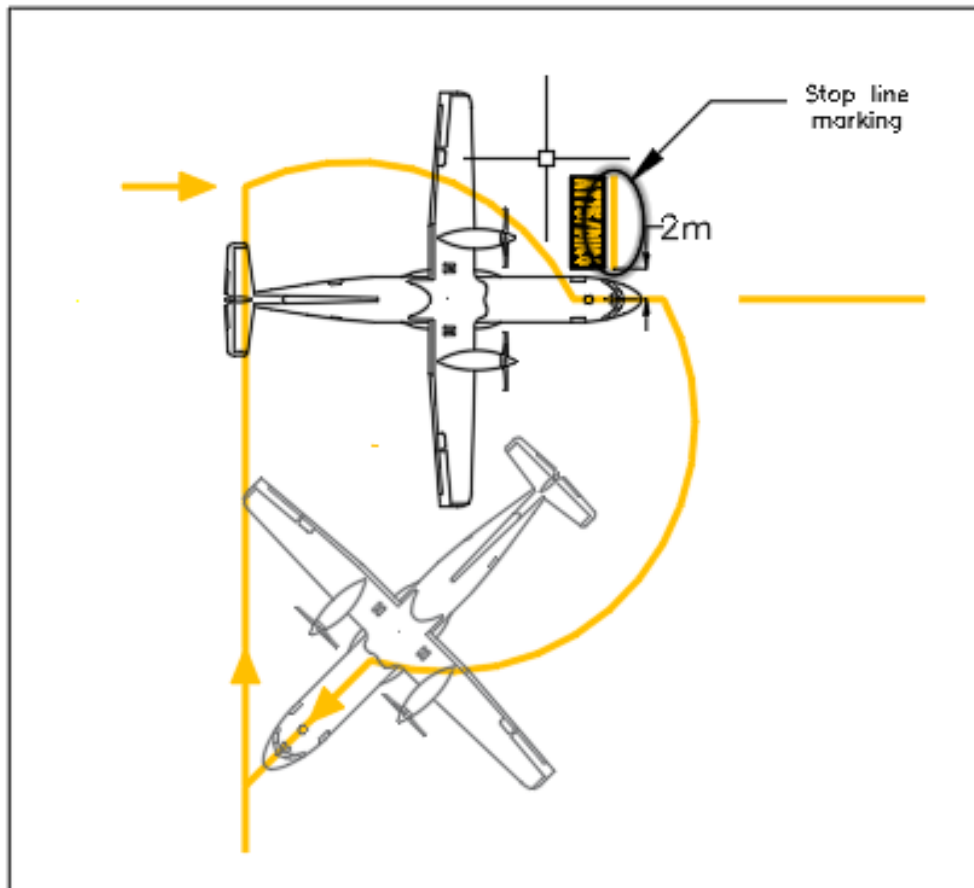

**Figure 4-10. Example of Stop Line Marking**

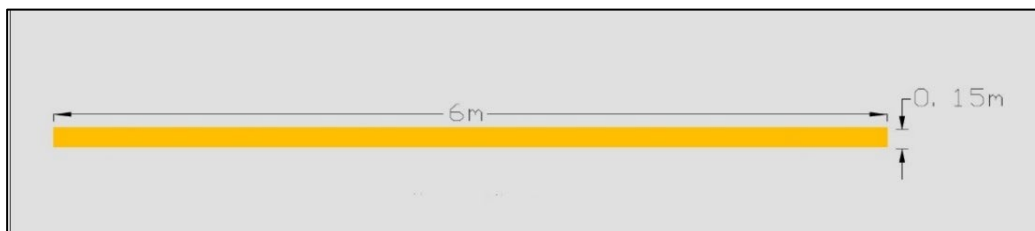
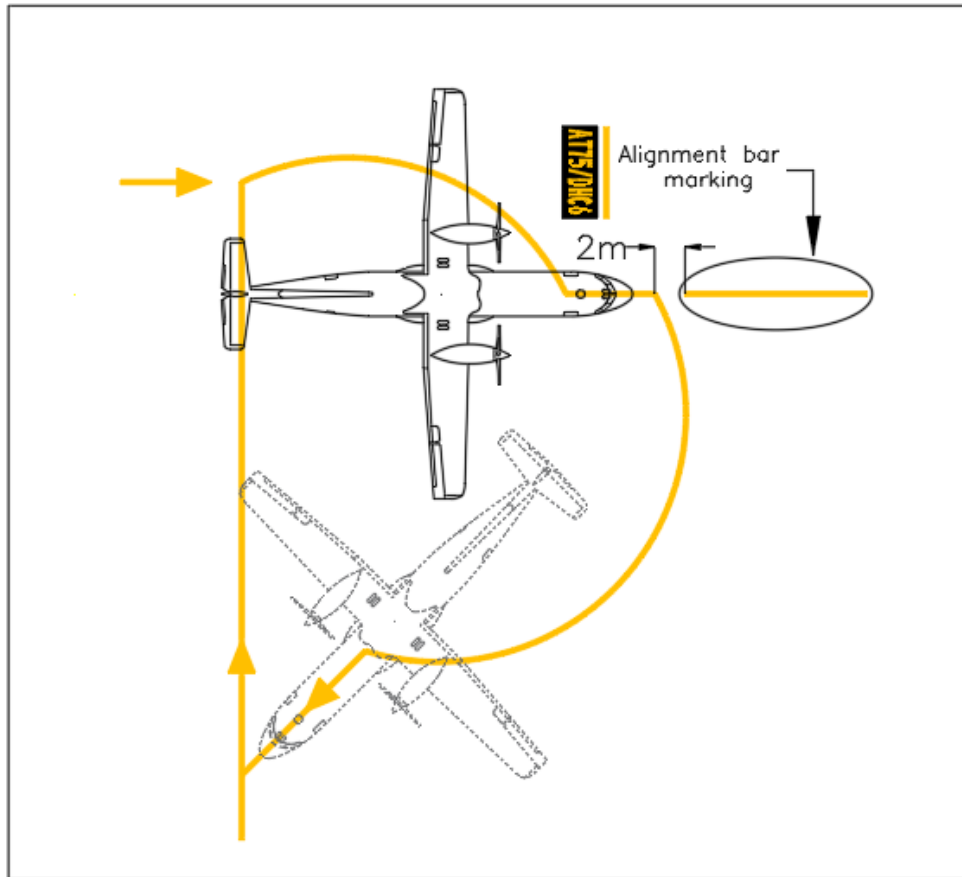

**Figure 4-11. Stop Line Marking**

#### 4.11 Alignment Bar

- a) Purpose – Alignment bar assists in aligning the aircraft on the desired angle.
- b) Location – An alignment bar shall be placed so as to be coincident with the extended centre line of the aircraft in the specified parking position and visible to the pilot during the final part of the parking manoeuvre.
- c) Characteristics – It shall have a length and width of not less than 15 m and 0.15 m respectively.

*Note. – Where space is limited, the length of alignment bar can be reduced subject to approval by CAAM Air Navigation Services & Aerodrome.*



**Figure 4-12. Example of Alignment Bar Marking**

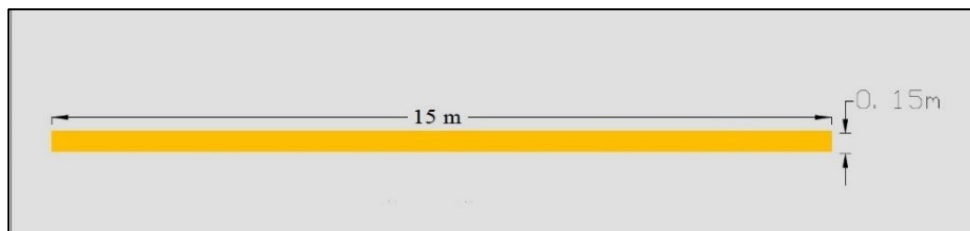

**Figure 4-13. Alignment Bar Marking**

4.12 Arrow Marking

a) Purpose – Where it is intended that an aircraft proceed in one direction only, arrow pointing in the direction to be followed shall be added as part of the lead-in and lead-out lines.

b) Characteristics

Dimension	A	2.0 m
	B	2.0 m

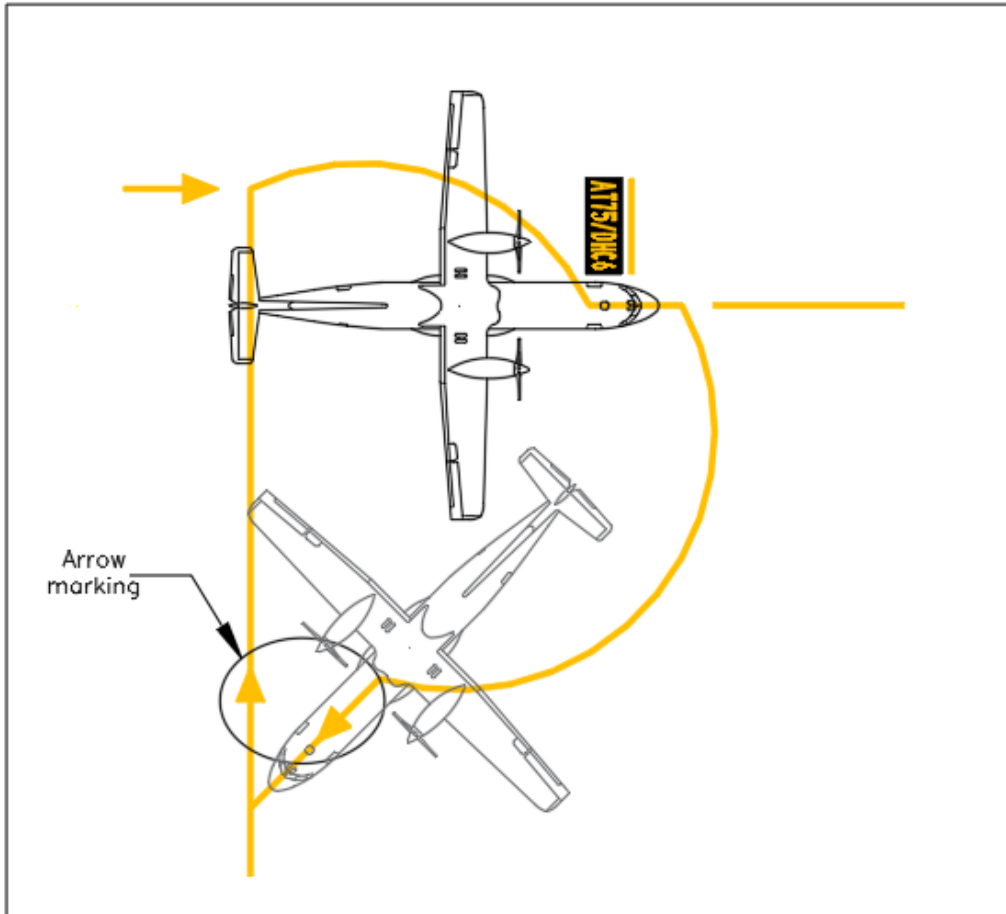

**Figure 4-14. Example Arrows Marking**

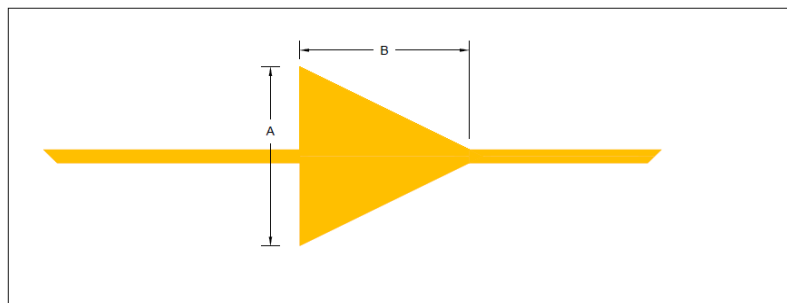

**Figure 4-15. One Way Arrow Marking**

4.13 Aircraft Stand Identification Marking

- a) For the purpose of indicating the location, an aircraft stand identification marking shall be established on the surface of the pavement.

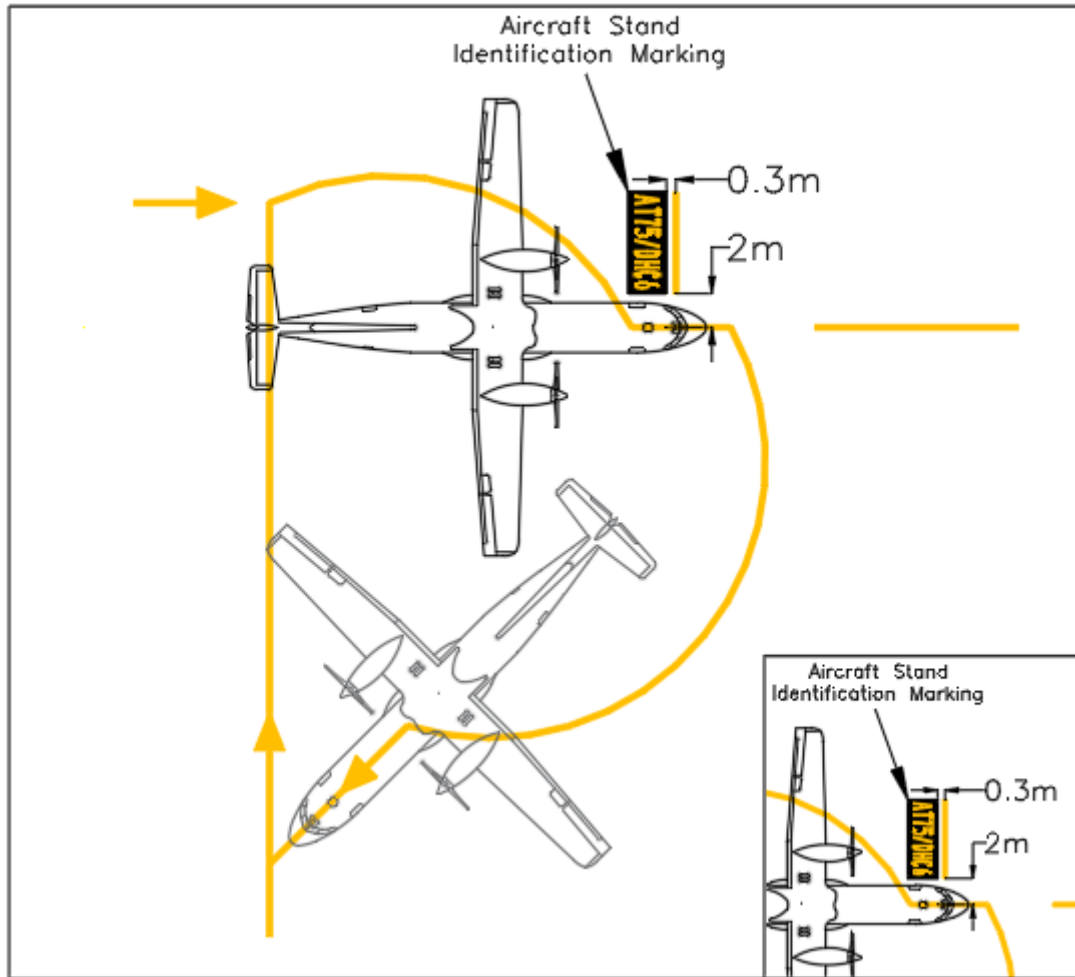
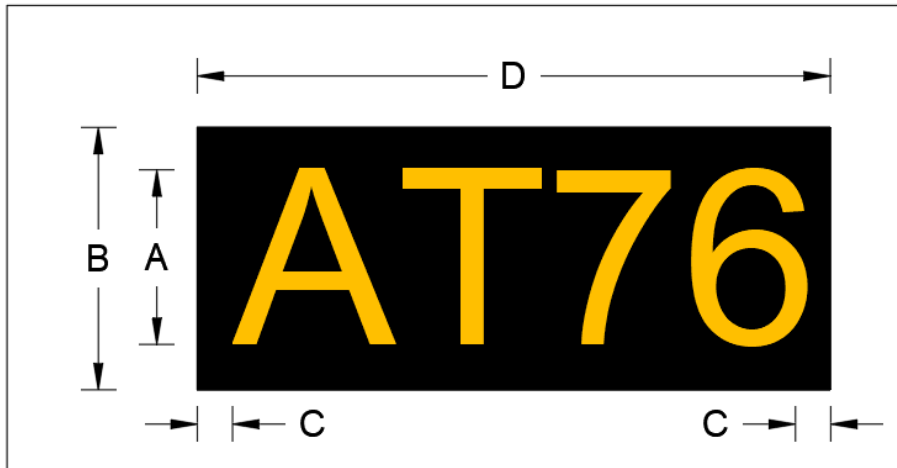

**Figure 4-16. Example of Stand Identification Marking**

4.13.1 Single aircraft type

**Characteristic**

Dimension	A	1.0 m
	B	1.5 m
	C	0.15 m
	D	According to character width

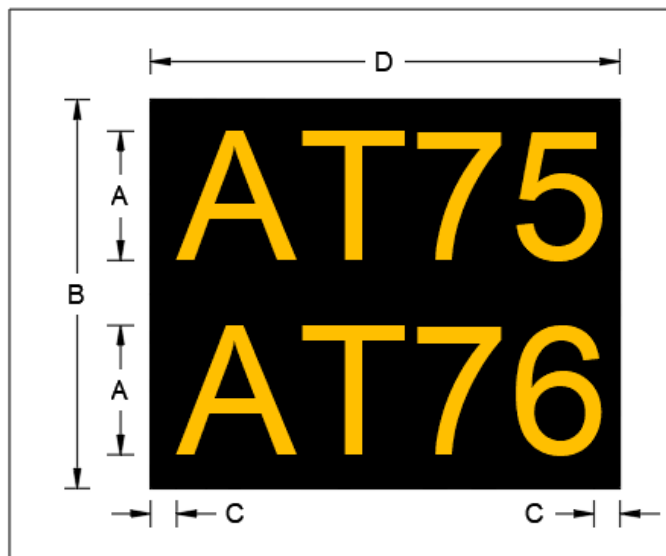

**Figure 4-17. Single aircraft type**

4.13.2 Multiple aircraft type

**Characteristic**

Dimension	A	1.0 m
	B	3.0 m
	C	0.15 m
	D	According to character width



**Figure 4-18. Multiple aircraft type**

4.13.3 Multiple aircraft type

**Characteristic**

Dimension	A	1.0 m
	B	1.5 m
	C	0.15 m
	D	According to character width



Figure 4-19. Multiple aircraft type

## 5 PIPB Markings

5.1 PIPB Markings shall consist of:

- a) Lead-in line
- b) Stop line
- c) Aircraft Stand identification

5.1.1 Lead-in Line Marking

- a) Purpose – This line provides guidance from apron taxiway or aircraft stand taxilane into specific aircraft stands.

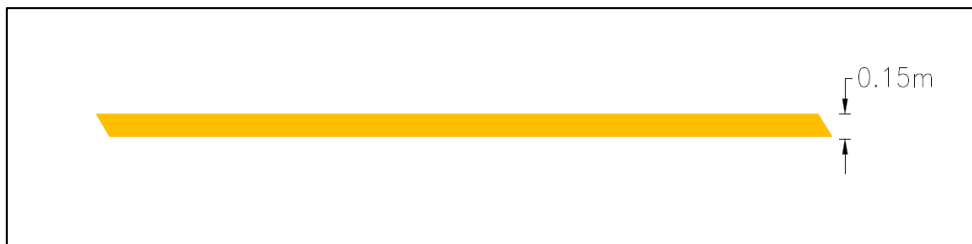

**Figure 5-1. Lead-in Line Marking**

- b) There are three types of Lead-in Line Marking:

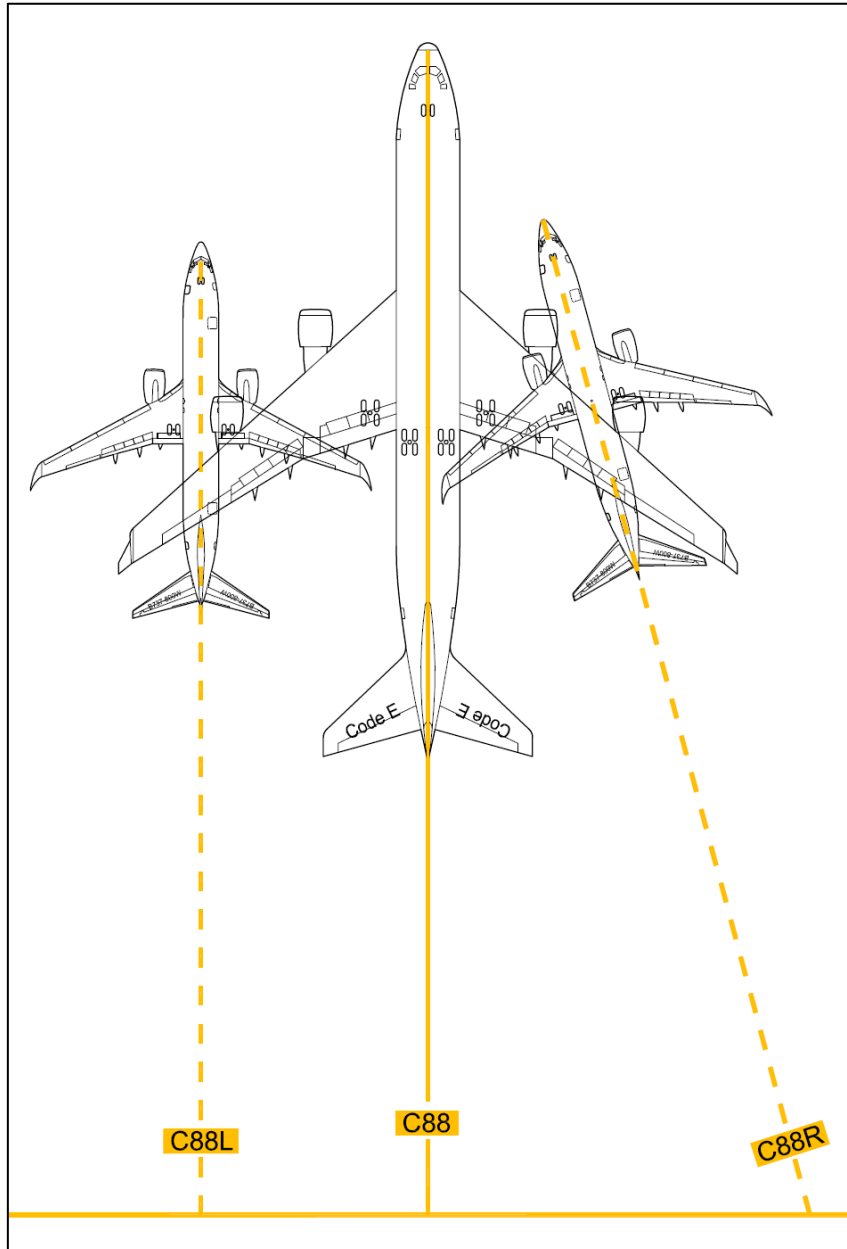

Figure 5-2. Type 1 – Lead-in Line Marking



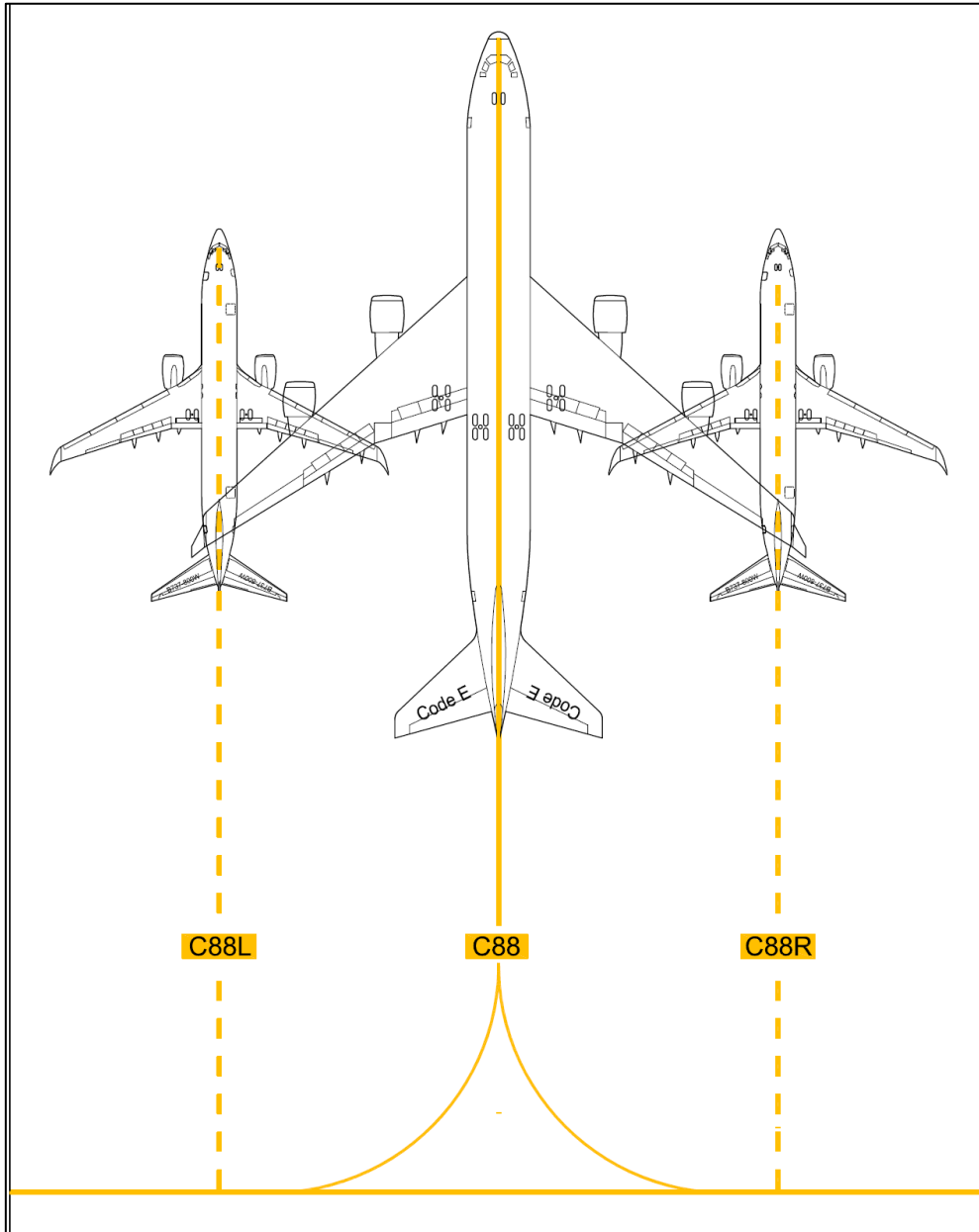
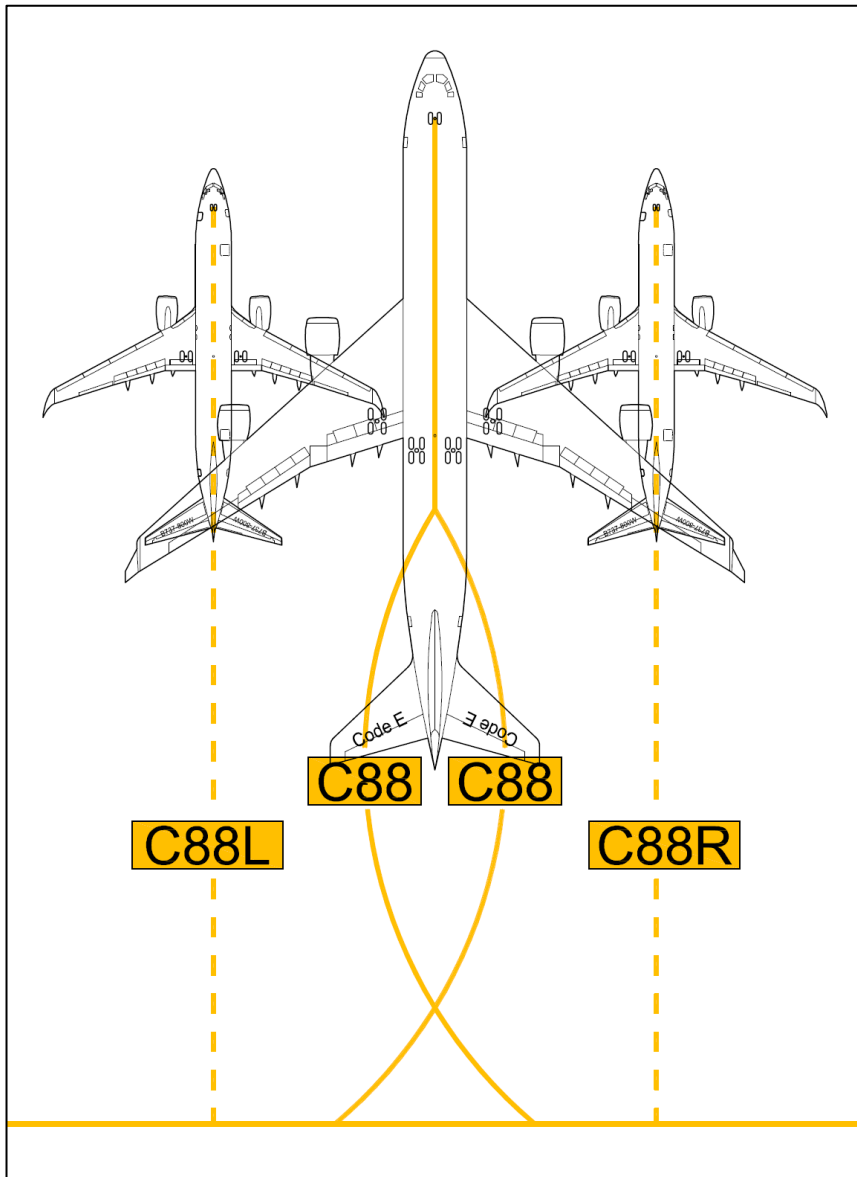

Figure 5-3. Type 2 – Lead-in Line Marking



**Figure 5-4. Type 3 – Lead-in Line Marking**

5.2 Direction to Aircraft Parking Stand Marking

- a) Purpose – This line assists the pilot of an approaching aircraft to identify the appropriate aircraft parking stand, prior to initiating a turn.

**Characteristic**

Dimension	A	4.0 m
	B	5.0 m
	C	0.15 m
	D	According to character width

*Note. – Where space is limited, especially when parking stands have multiple centre line, the character size may be reduced, subject to approval CAAM Air*

Navigation Services & Aerodrome. However, the character height should be not less than 2 m.

Dimension	A	2.0 m
	B	3.0 m
	C	0.15 m
	D	According to character width

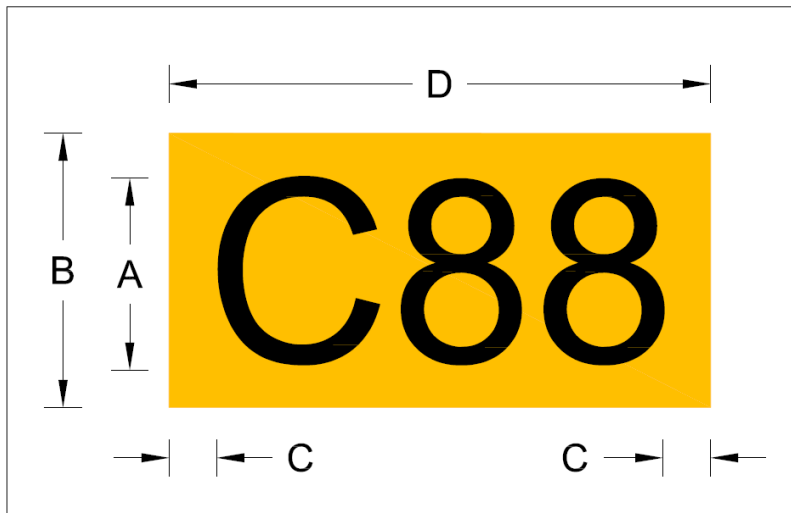

Figure 5-5. Example of Aircraft Stand Number

5.2.1 Direction to Aircraft Parking Stand Marking

**Characteristic**

Dimension	A	0.5 m
	B	1.0 m

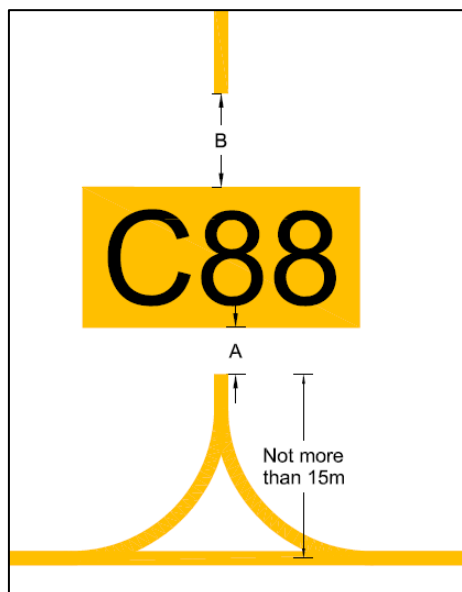

Figure 5-6. Type 1 - Direction to Aircraft Stand

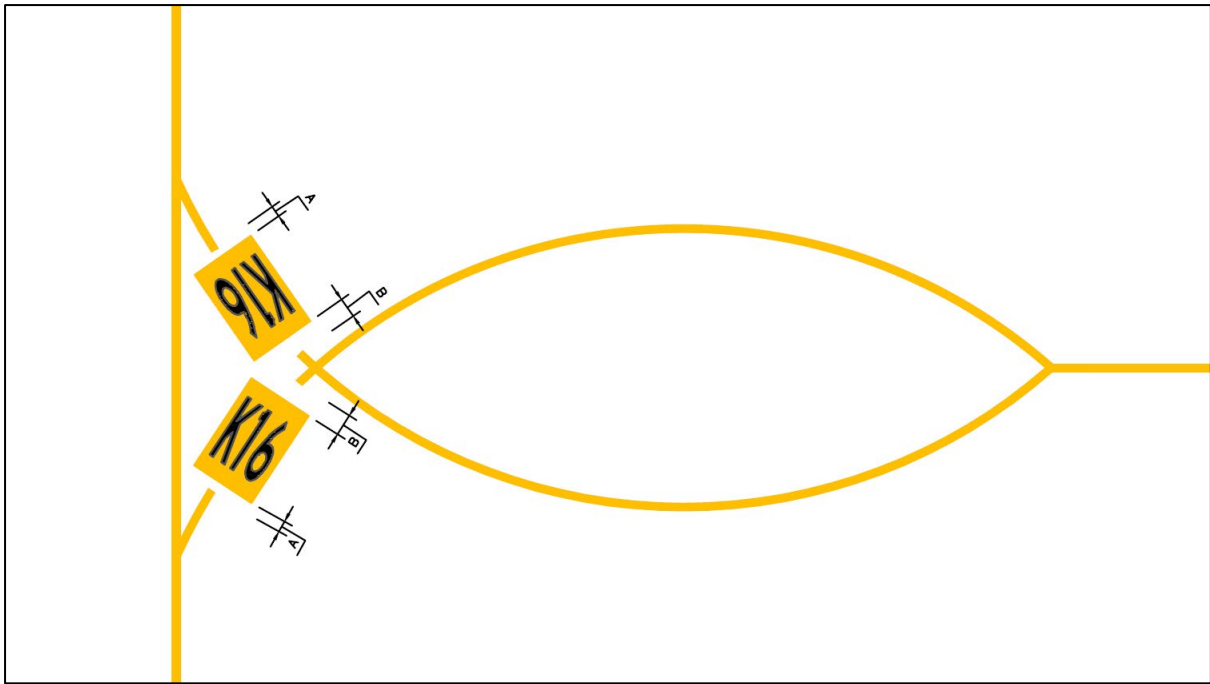

Figure 5-7. Type 2 - Direction to Aircraft Stand

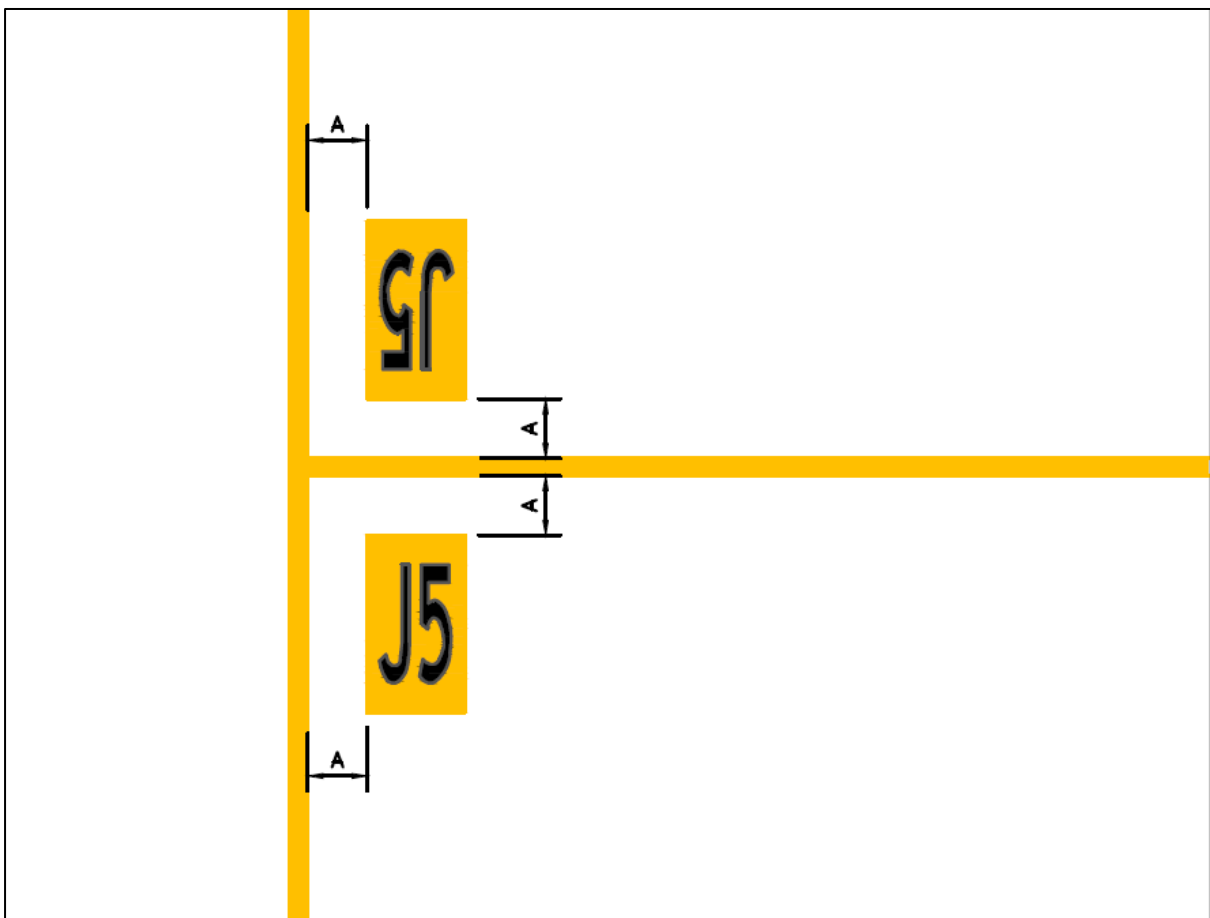

Figure 5-8. Type 3 - Direction to Aircraft Stand

5.3 Stop Line Marking

a) Purpose – This line indicates the point at which aircraft need to stop.

5.3.1 Single Aircraft Type Stop Line Marking

**Characteristic**

Dimension	A	1.0 m
	B	0.3 m

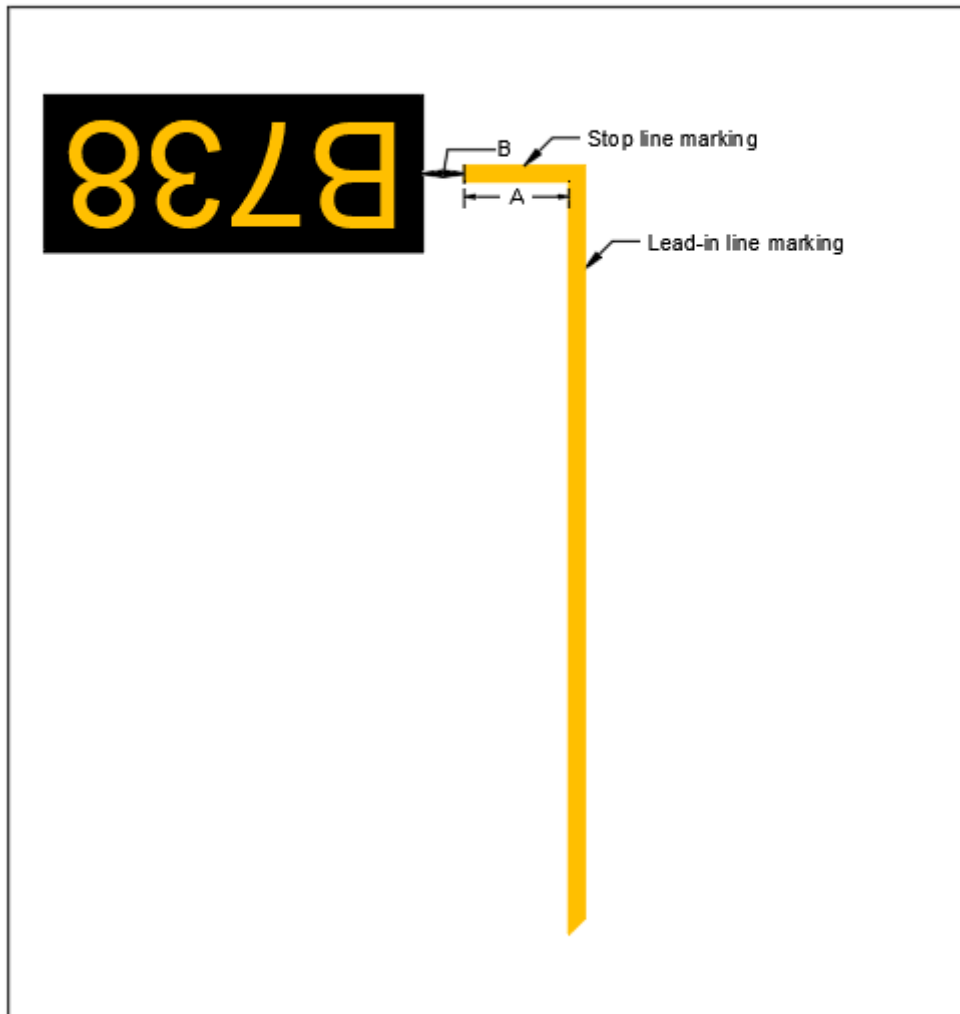

**Figure 5-9. Single Aircraft Type Stop Line Marking**

5.3.2 Multiple Aircraft Type with Same Stop Line Marking

**Characteristic**

Dimension	A	1.0 m
	B	0.3 m

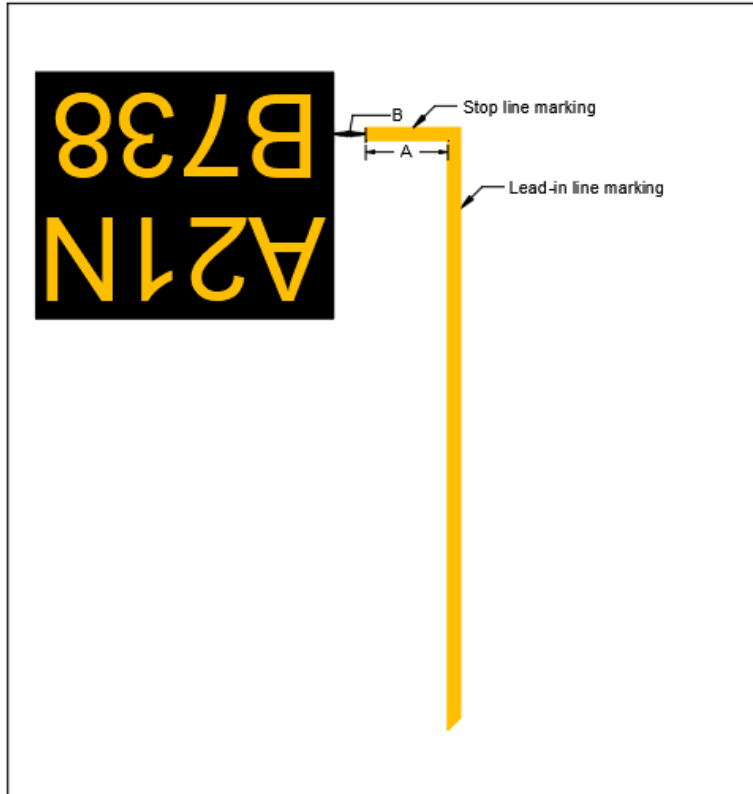

Figure 5-10. Option 1 - Multiple Aircraft Type with Same Stop Line Marking

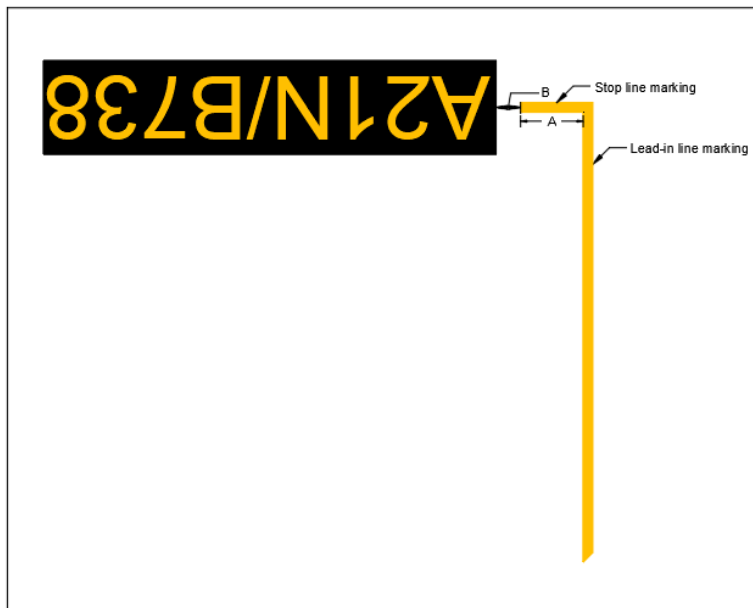

Figure 5-11. Option 2 - Multiple Aircraft Type with Same Stop Line Marking

5.3.3 Multiple Aircraft Type with Different Stop Line Marking

**Characteristic**

Dimension	A	1.0 m (minimum)
	B	0.3 m

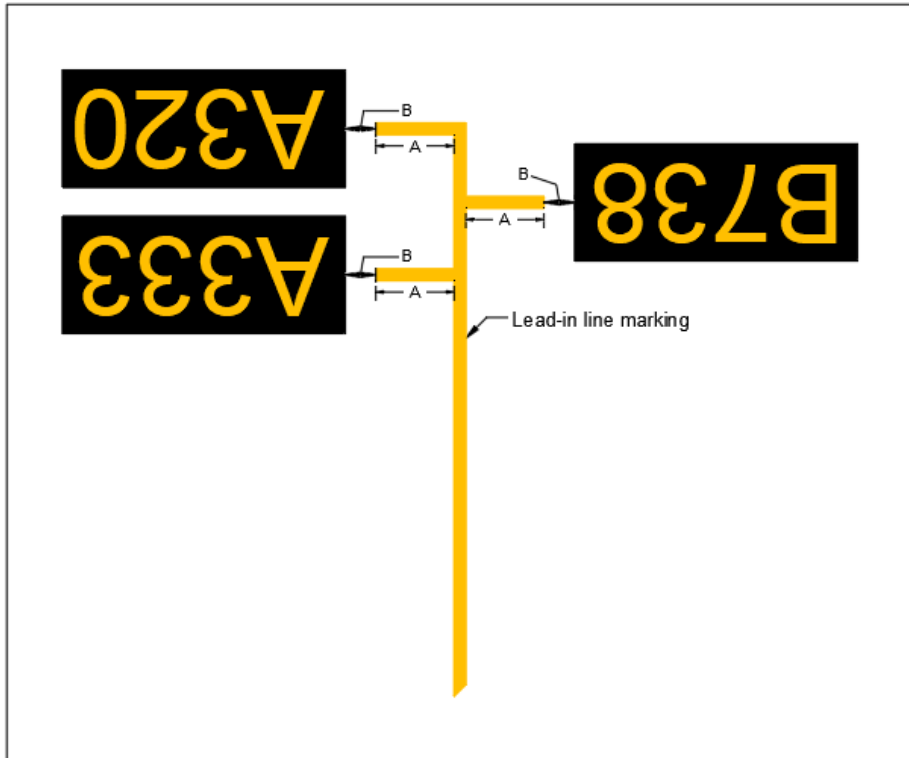

Figure 5-12. Option 1 - Multiple Aircraft Type with Different Stop Line Marking

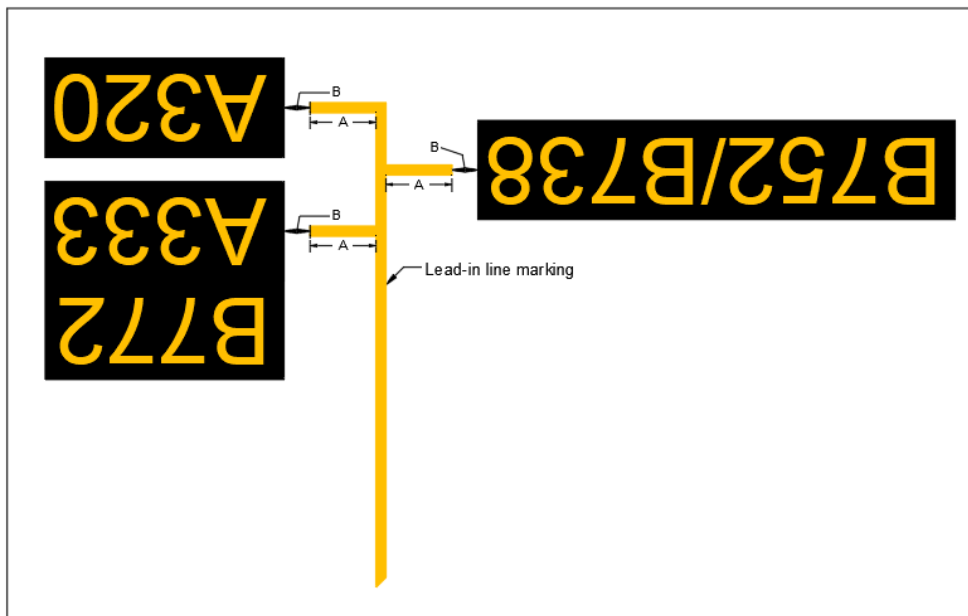

Figure 5-13. Option 2 - Multiple Aircraft Type with Different Stop Line Marking

5.4 Aircraft Stand Identification Marking

- a) Purpose – To indicate the location, an aircraft stand identification marking shall be established on the surface of the pavement.

*Note. – Where space is limited, the marking can be located at the left side of marshaller view.*

**Characteristic**

Dimension      A      0.3 m

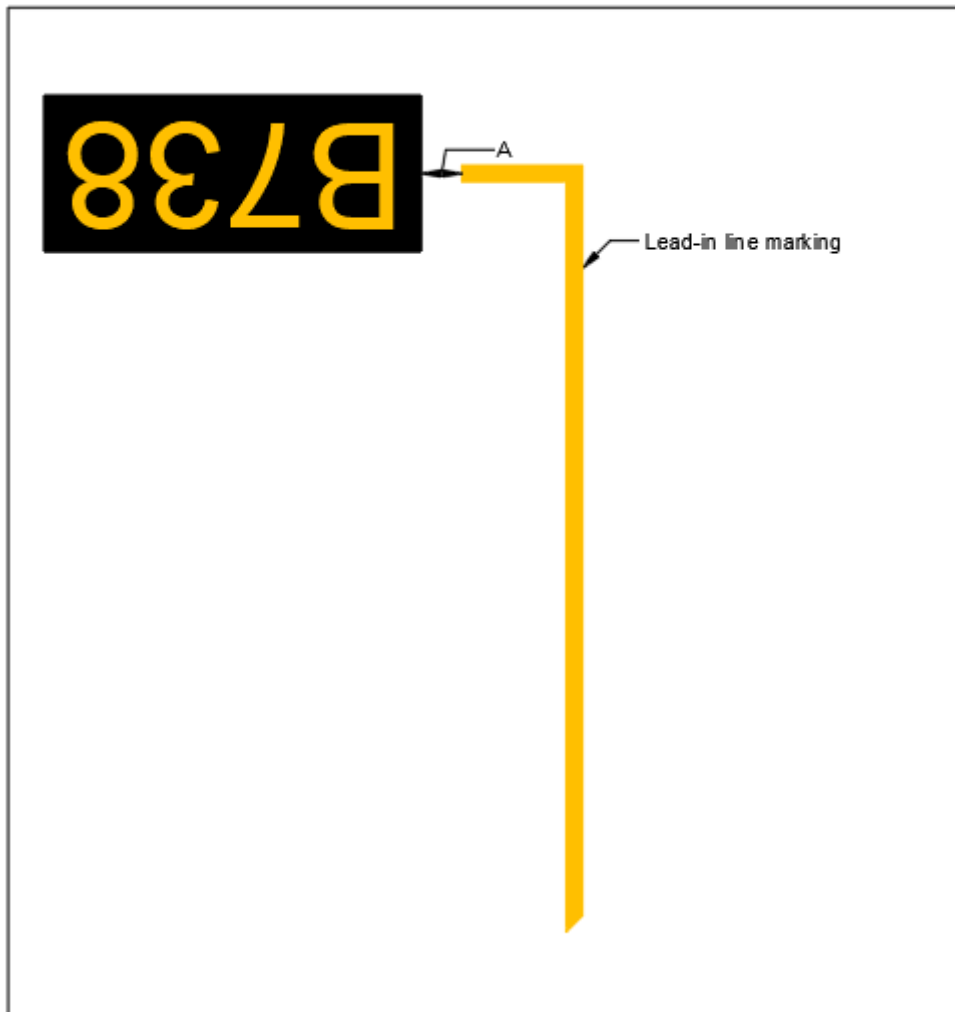

**Figure 5-14. Example of Aircraft Stand Identification Marking**

5.4.1 Single aircraft type

**Characteristic**

Dimension	A	1.0 m
	B	1.5 m
	C	0.15 m
	D	Acc. to character width



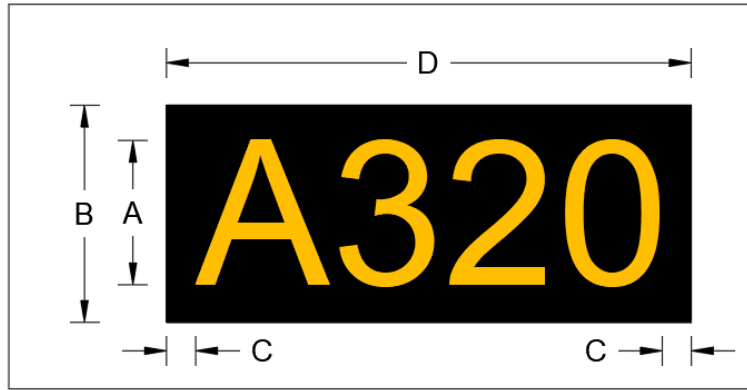
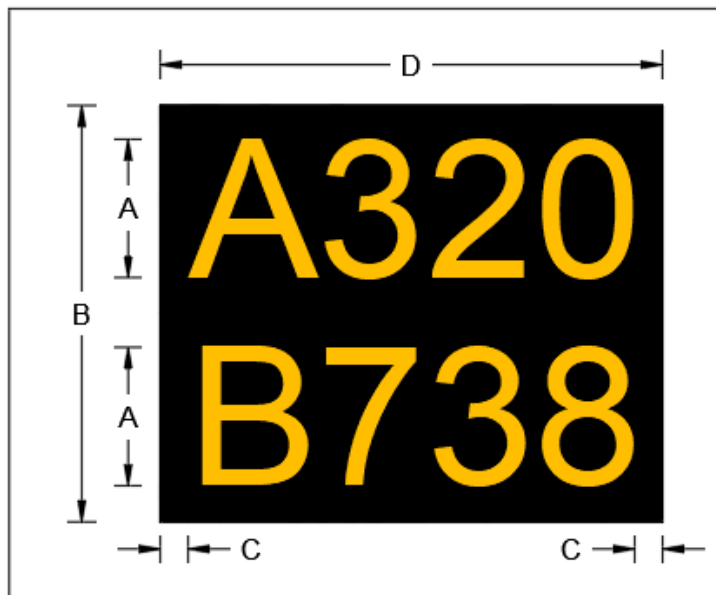

**Figure 5-15. Single Aircraft Type**

5.4.2 Multiple aircraft type 1

**Characteristic**

Dimension	A	1.0 m
	B	3.0 m
	C	0.15 m
	D	Acc. to character width

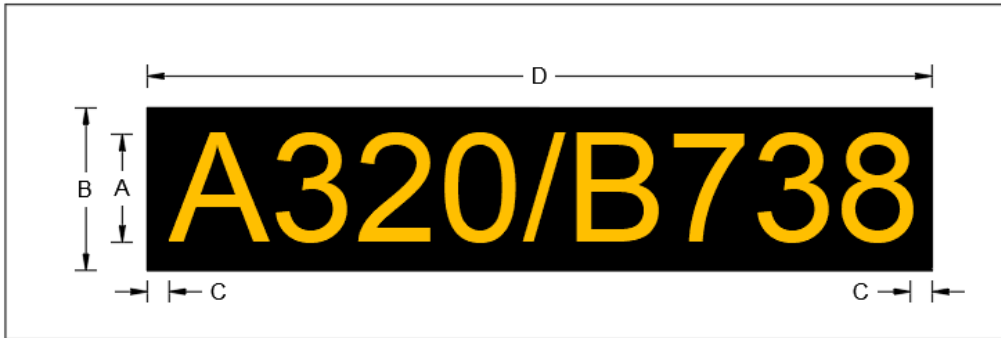

**Figure 5-16. Option 1 - Multiple Aircraft Type**

5.4.3 Multiple aircraft type 2

**Characteristic**

Dimension	A	1.0 m
	B	1.5 m
	C	0.15 m
	D	Acc. to character width



**Figure 5-17. Option 2 - Multiple Aircraft Type**

## 6 Taxi Side Stripe Marking on Apron Edge

- 6.1 Purpose – An apron edge is denoted by using taxi side stripe marking to delineate the boundary of apron area where the edge of the full-strength pavement cannot be easily distinguished, or when a low strength shoulder adjoins the full-strength pavement.

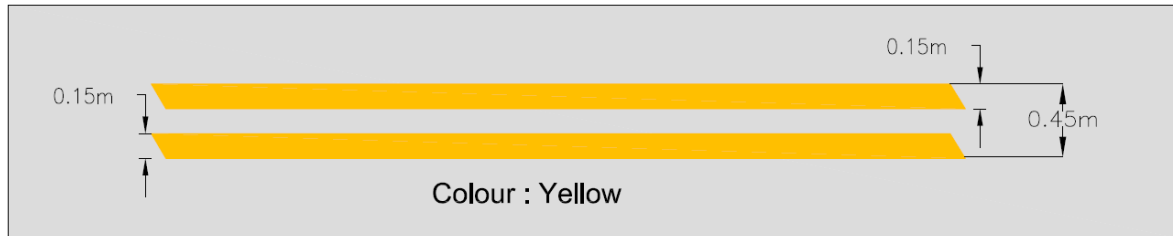

**Figure 6-1. Taxi Side Stripe Markings**



**INTENTIONALLY LEFT BLANK**

## 7 Apron Safety Line Marking

- 7.1 Purpose – Apron safety lines shall be provided on a paved apron as required by the parking configurations and ground facilities.
- 7.2 Location – Apron safety lines shall be located so as to define the areas intended for use by ground vehicles and other aircraft servicing equipment, etc., to provide safe separation from aircraft manoeuvring through the apron taxiway or aircraft stand taxilane.
- Note. – See Table 1-3 for location of apron safety line marking*
- 7.3 Characteristics – An apron safety line shall be continuous in length and at least 0.10 m in width. Apron safety lines shall be of a conspicuous colour which shall contrast with that used for aircraft stand markings.

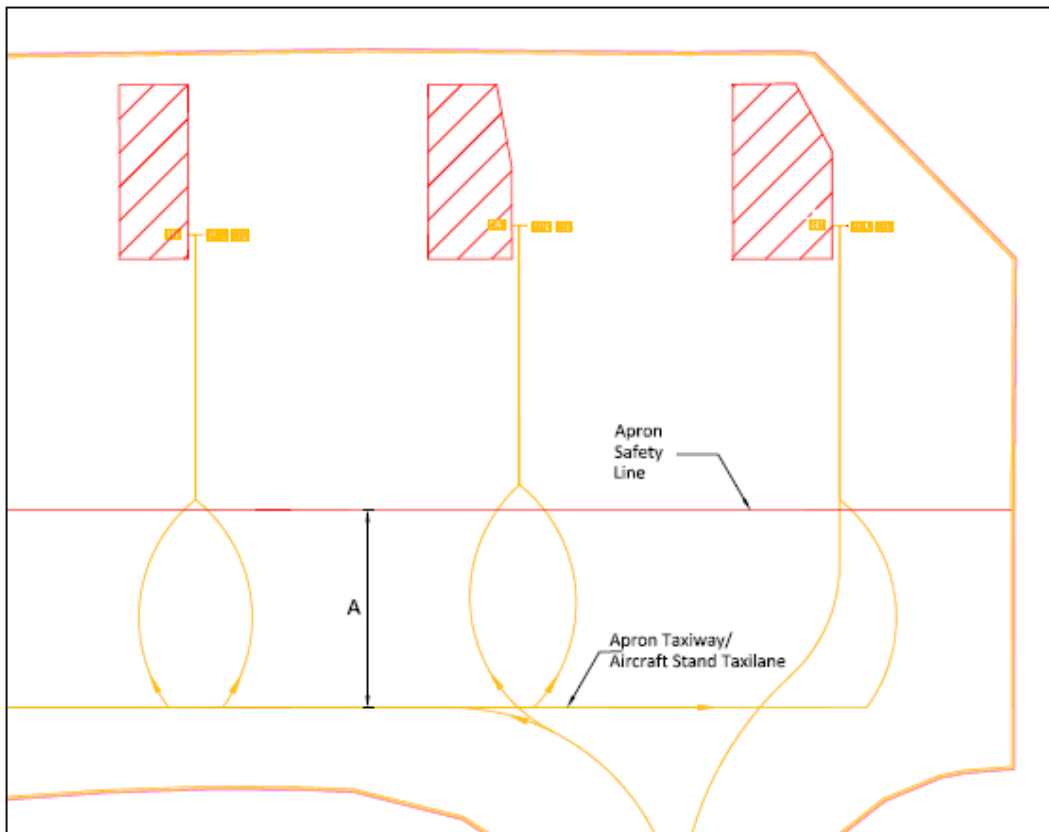

Figure 7-1. Location of apron safety line markings



Figure 7.2. Apron safety line markings



**INTENTIONALLY LEFT BLANK**

## 8 Secondary Markings for Lead-In, Turning, Lead-Out, Turn Bar, Alignment Bar and Stop Line

8.1 Purpose – Where one or more sets of stand markings are superimposed on a stand marking, the lines shall be continuous for the most demanding aircraft and broken for other aircraft.

8.2 Characteristic (Lead-in, Lead-out and Turning lines)

Dimension	A	0.15 m (minimum)
	B	2.0 m
	C	2.0 m

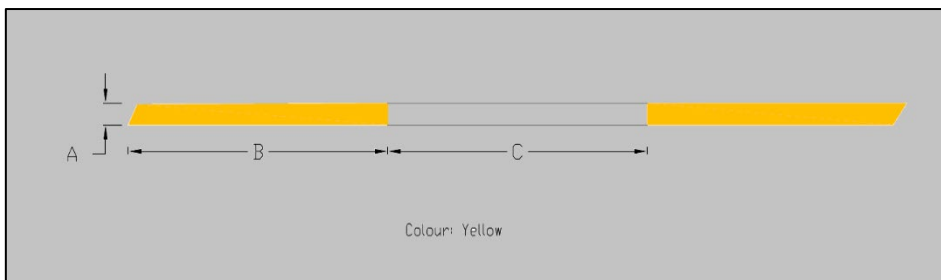

**Figure 8-1. Secondary marking for lead-in and lead-out lines**

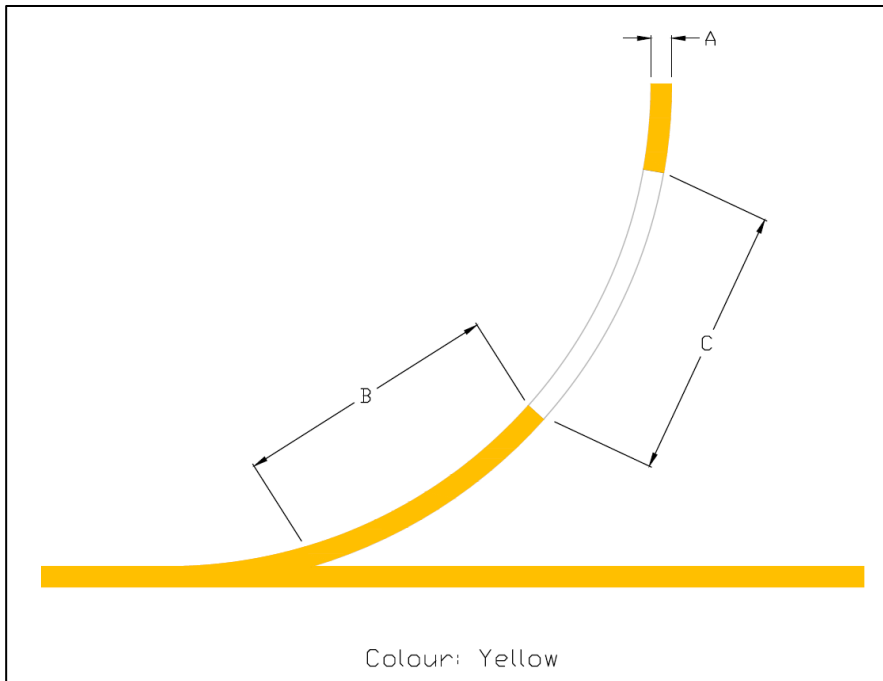

**Figure 8-2. Secondary marking for turning line**

8.3 Characteristic (Turn Bar)

Dimension	A	0.15 m (minimum)
	B	1.0 m
	C	0.5 m
	D	2.0 m
	E	2.0 m

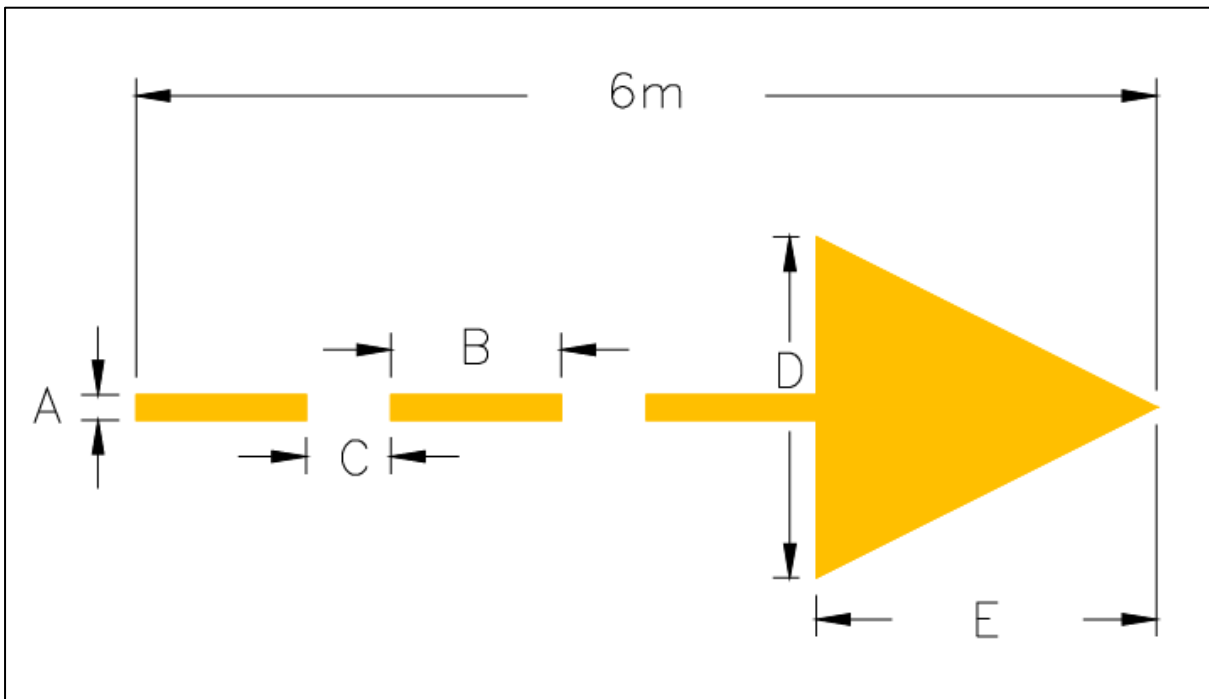
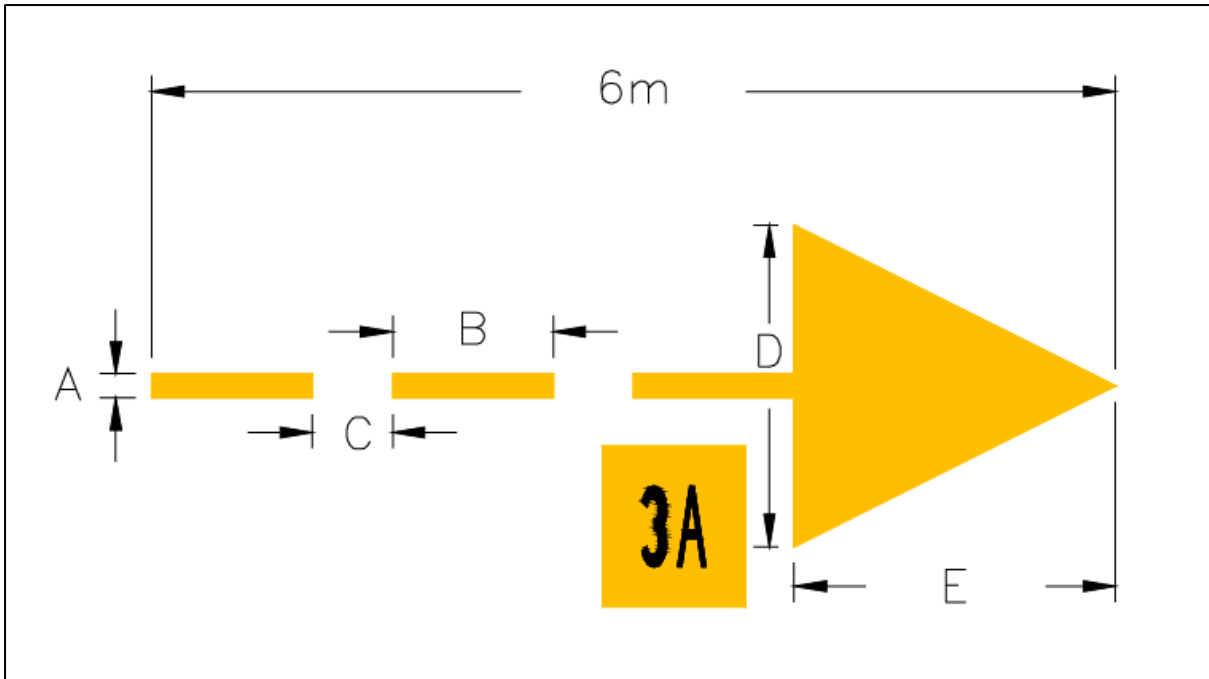

Figure 8-3. Secondary marking for turn bar



8.4 Characteristic (Alignment Bar)

Dimension	A	0.15 m (minimum)
	B	2.0 m
	C	1.25 m

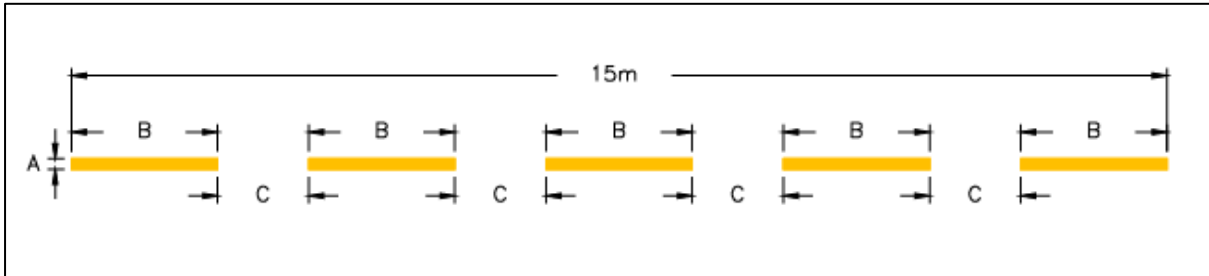

Figure 8-4. Secondary marking for alignment bar

8.5 Characteristic (Stop Line)

Dimension	A	0.15 m (minimum)
	B	1.6 m
	C	0.6 m

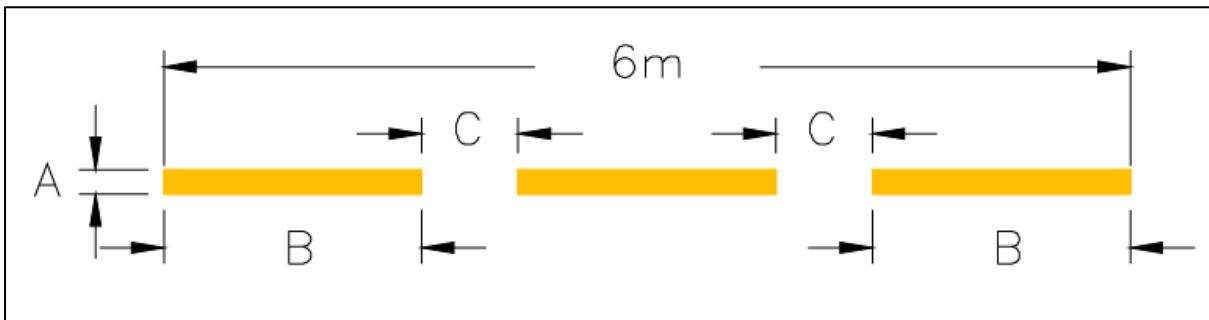

Figure 8-5. Secondary marking for stop line



**INTENTIONALLY LEFT BLANK**

## 9 Stop Line marking for No Passenger Boarding Bridge (PBB) Operations

9.1 Purpose – To provide stop line marking for aircraft which does not use PBB even though PBB is available.

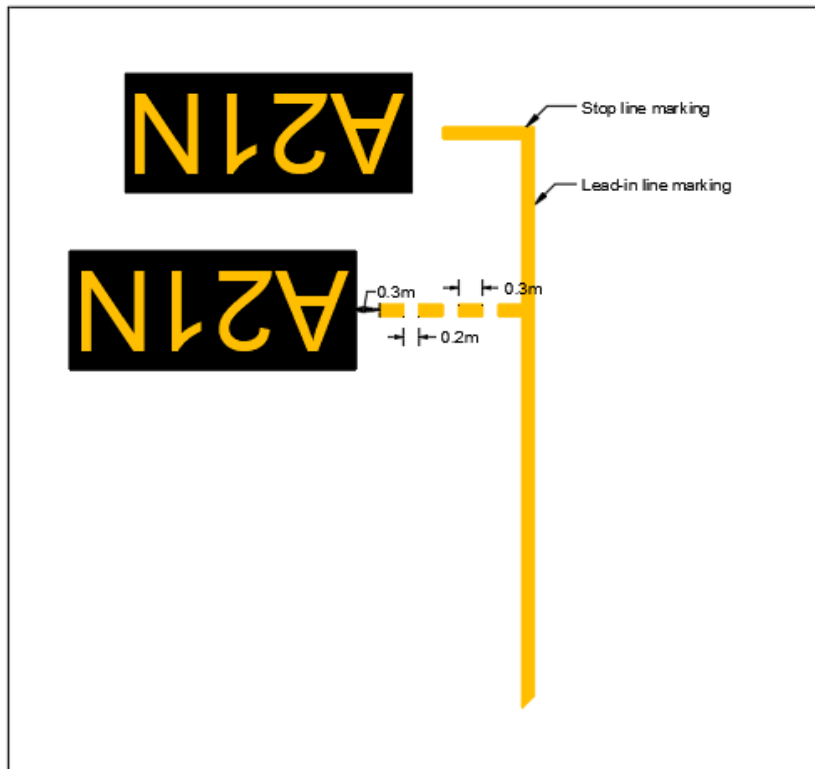

**Figure 9-1. Stop Line Marking for NO PBB Operations**

*Note A. – During establishing NO PBB marking, safety clearance between aircraft tail and apron safety line must take into consideration.*



**INTENTIONALLY LEFT BLANK**

## 10 Aircraft Engine Start-Up Position Line Marking

10.1 Purpose – To provide stop position for aircraft to conduct engine start-up.

### 10.2 Characteristic

Dimension	A	1.0 m
	B	0.1 m
	C	0.5 m
	D	0.3 m
	E	0.1 m
	F	0.2 m
	G	0.2 m

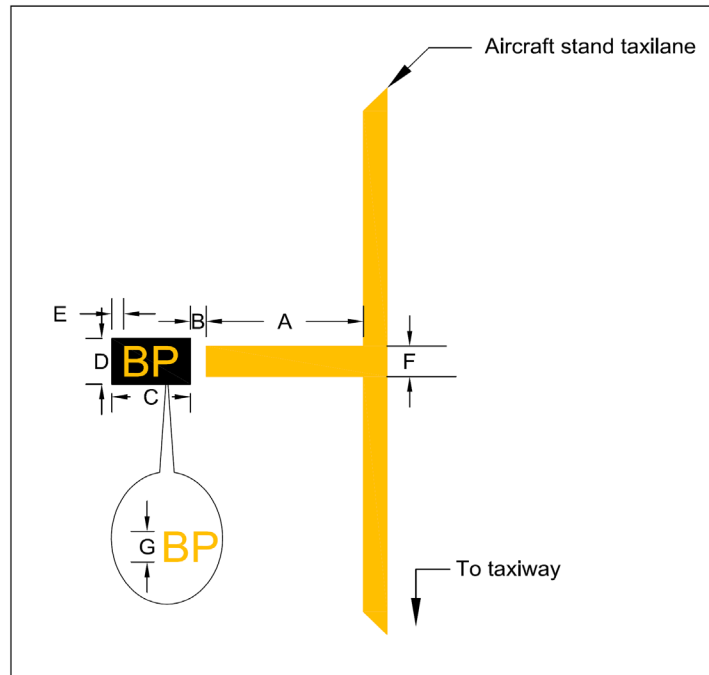

Figure 10- 1. Aircraft Engine Start-up Position Line Marking



Figure 10-2. Aircraft Engine Start-up Position Line Marking



**INTENTIONALLY LEFT BLANK**

## 11 No Parking Area Marking

11.1 Purpose – No parking area for vehicles is indicated by red hatching within a red border.

### 11.2 Characteristic

Dimension	A	0.1 m (minimum)
	B	0.5 m – 1.0 m
Colour	Border	Red
	Hatching	Red

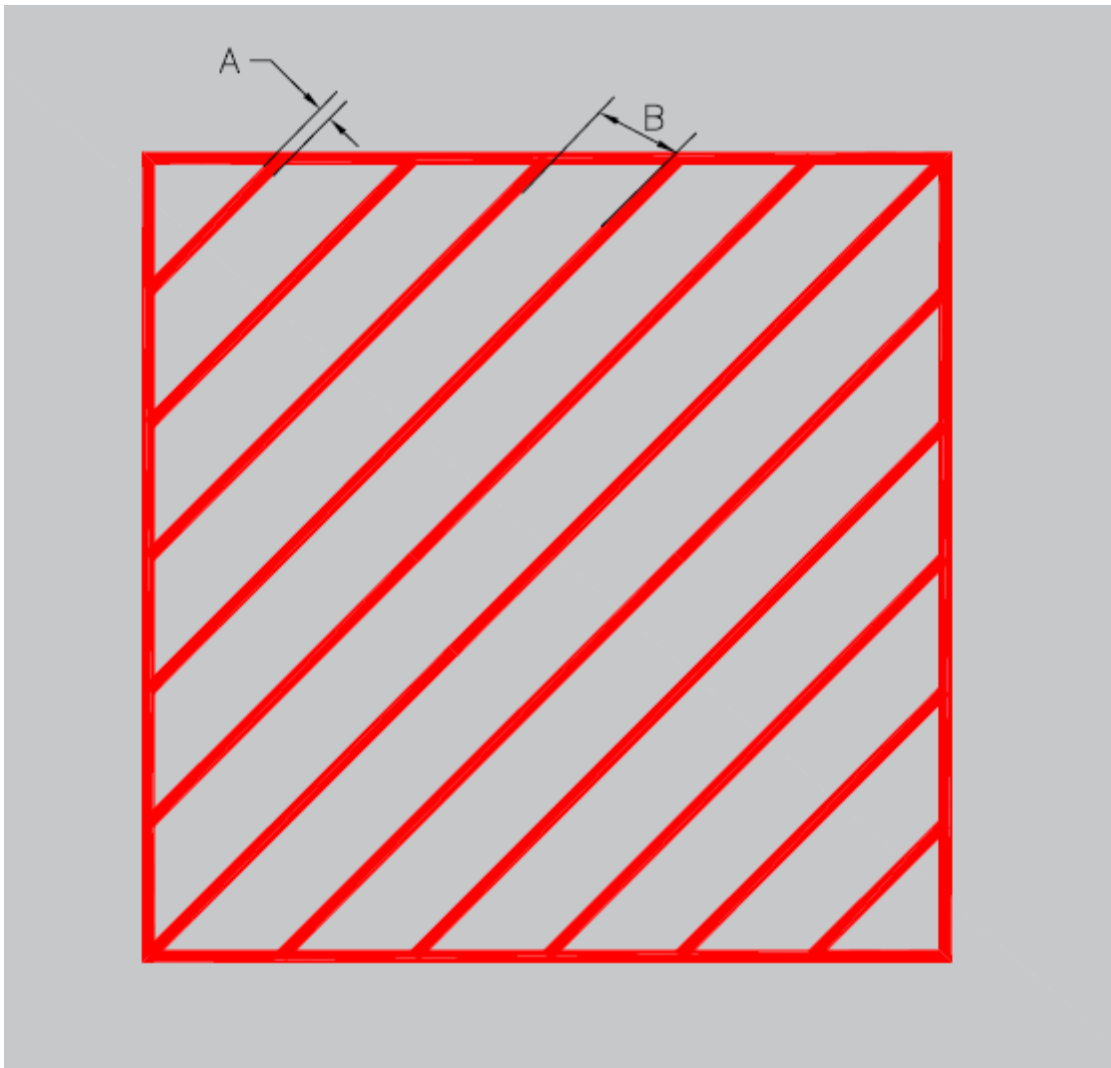

Figure 11-1. No parking area markings



**INTENTIONALLY LEFT BLANK**



## 12 PBB Wheel Position

- 12.1 Purpose – The area under PBB has to be kept free of vehicles and equipment to ensure the safe operation of the PBB. PBB wheel positions is to show the location at which PBB wheels should be located at safe position when not in use and to allow aircraft to enter the stand safely.
- 12.2 When the wheel of PBB is at PBB wheel position marking, the distance between the nearest structure of PBB and the aircraft shall comply with requirement mentioned in Table 1-2.
- 12.3 PBB wheel position can be either in the form of a circle or a rectangular. The dimension of PBB wheel position marking is based on the outer width of PBB wheels. The distance between the outer wheel of the PBB and the edge of the marking (border) should be not more than 0.5 m.

### 12.4 Characteristic

Dimension	Size of marking	Based on size of PBB wheel
	Border width	0.1 m (minimum)
Colour	Border	Red
	Wheel position parking circle/rectangular	White

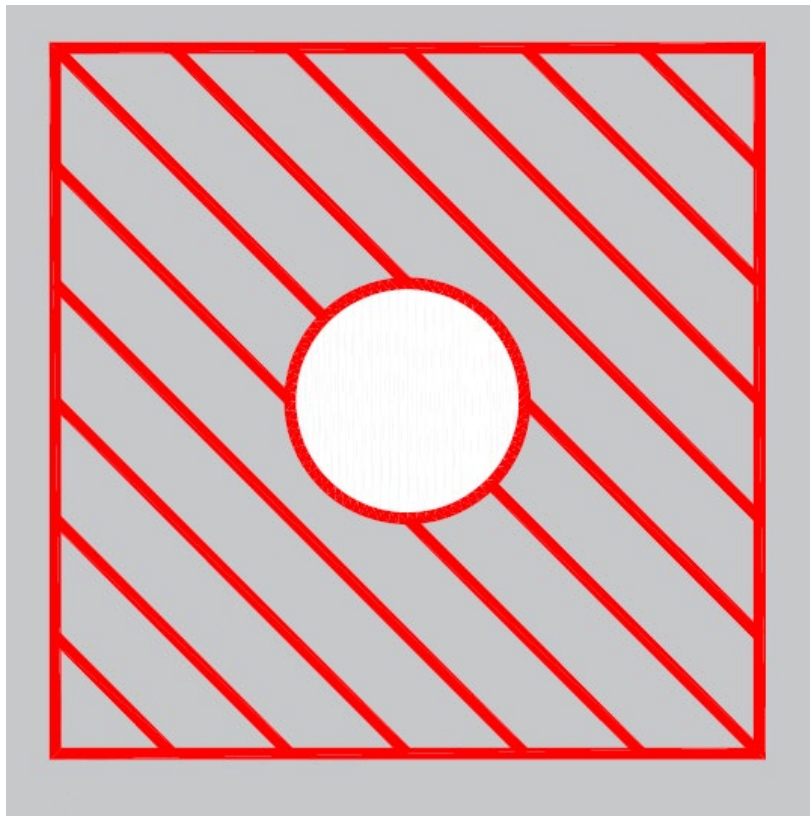
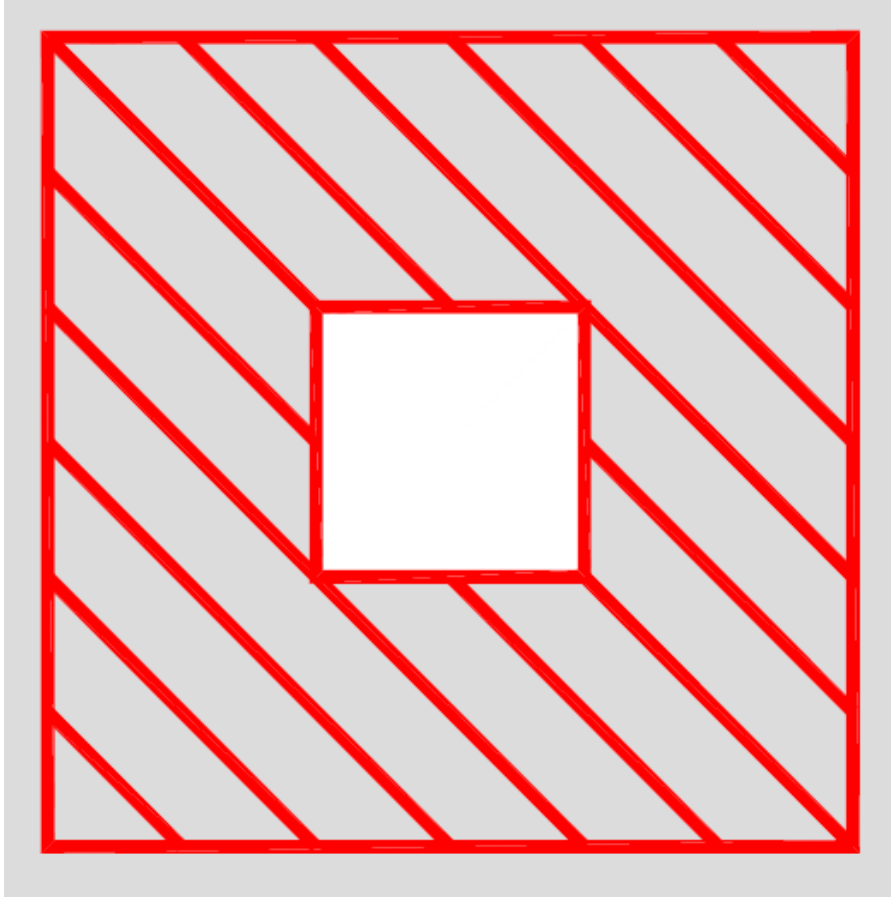

Figure 12-1. PBB wheel position markings



**Figure 12-2. PBB wheel position markings**

## 13 Fuel Hydrant Marking

13.1 Purpose – This marking is indicative of the markings used with all underground services. The size and shape of the markings depends on the size of the service opening. Any above ground projection, such as a lift-up hydrant connection system or cover, should be painted red.

### 13.2 Characteristic

Dimension	A	0.2 m (minimum)
Size of box	Based on size of manhole cover	
Colour	Red	

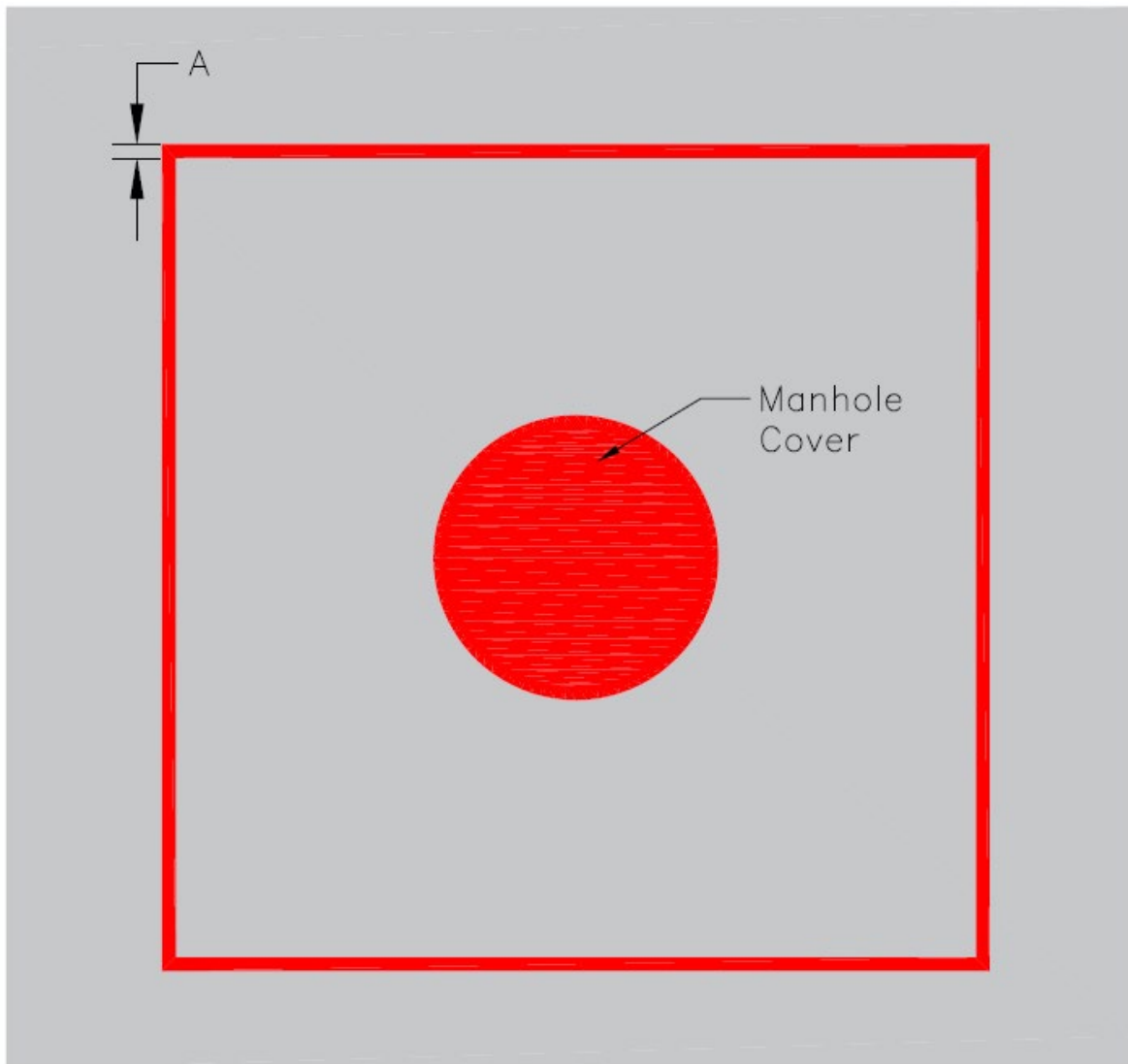

**Figure 13-1. Fuel hydrant markings**



**INTENTIONALLY LEFT BLANK**

## 14 Tractor Pushback Line and Pushback Limit Line Marking

- 14.1 Purpose – This line marking is to guide tractor (tug driver) when pushing back an aircraft from its stand. It is to ensure sufficient obstacle clearance on stands where clearances around manoeuvring aircraft are restricted.
- 14.2 A pushback limit line indicates the position where the aircraft (nose wheel) is to be stopped, prior to being disconnected from the tractor (tug).
- 14.3 The width of the marking should be 0.1 m.

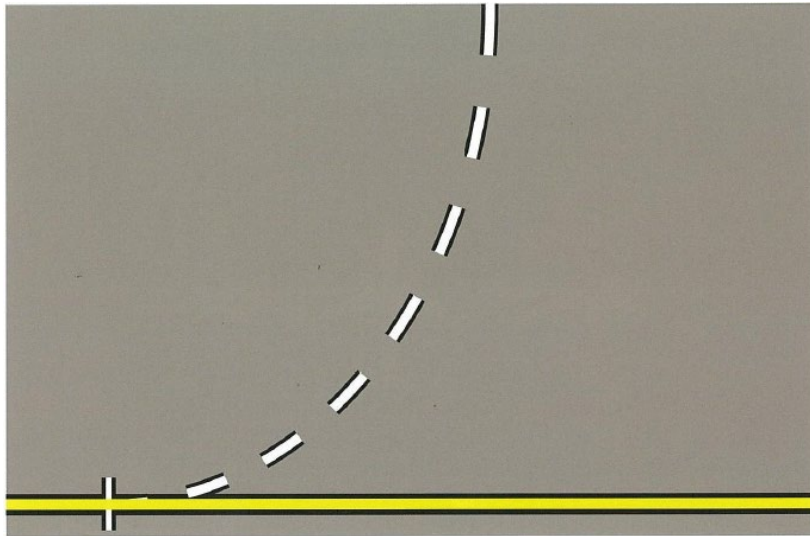

**Figure 14-1. Example of pushback line and pushback limit line**

### 14.4 Characteristic

Dimension	A	0.1 m (minimum)
	B	1.0 m
	C	1.0 m
	D	1.0 m
	E	0.1 m
Colour	Centre line / Bar	White
Border	Black	

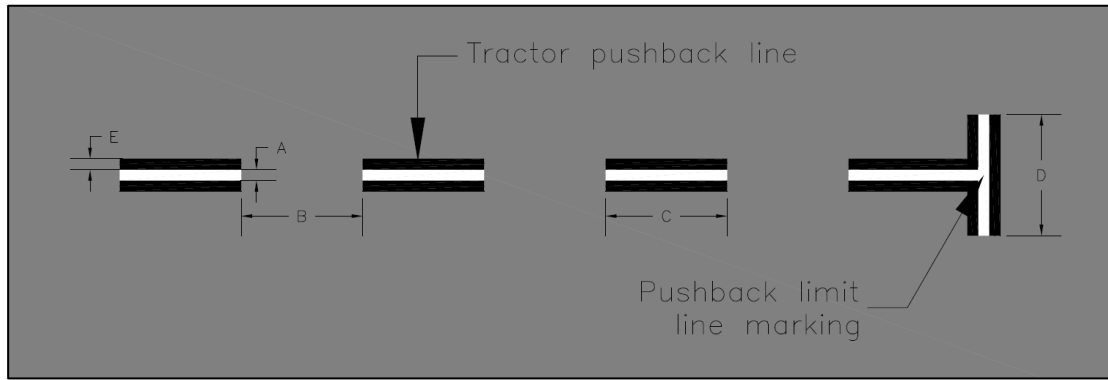

**Figure 14.2. Tractor pushback line and pushback limit line marking**

## 15 Vehicle and Equipment Parking Area

- 15.1 Purpose – This line is used to delineate limits of areas which are intended for parking of vehicles and aircraft servicing equipment where they are not in used.
- 15.2 However, vehicles shall never block emergency egress from buildings, nor restrict access to firefighting equipment, fuel shut-off valves and other life safety devices.
- 15.3 The shape and size of Vehicle and Equipment Parking Area Marking may not be restricted to square or rectangle only. It has to suit the available space for the vehicle and parking area.

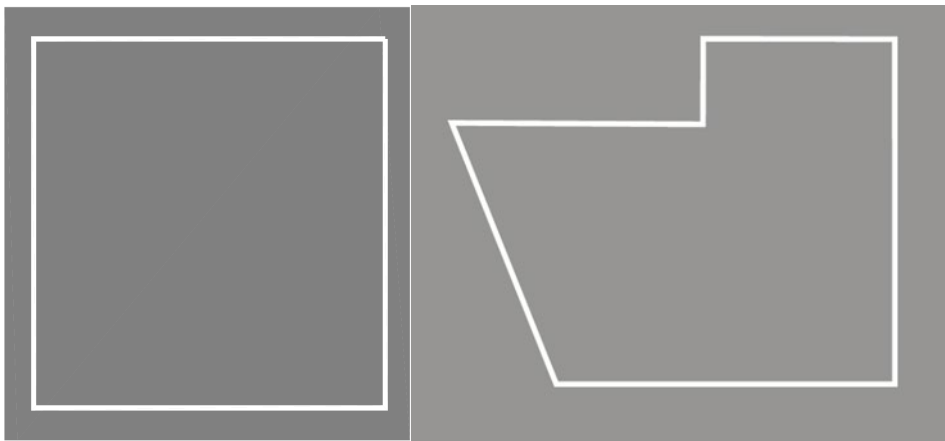

Figure 15-1. Example of equipment parking area marking

### 15.4 Characteristic

Dimension	A	0.1 m (minimum)
Colour	Line	White



Figure 15-2. Equipment parking marking



**INTENTIONALLY LEFT BLANK**



## 16 Nose Tip Clearance Lines

- 16.1 Purpose – This line depicts the area (at nose tip section) that must remain free of staff, vehicles and equipment when an aircraft is taxiing (or being towed) into position or has started engines in preparation for departure. Once all engine has been shut down and the anti-collision lights have been switched off, vehicles may cross the line to service the aircraft.
- 16.2 Characteristics – This line shall be continuous in length and at least 0.10 m in width. This line shall be red in colour.
- 16.3 If the line coincides with No Parking Area Marking, the line should be painted on top of No Parking Area Marking.

*Note. – This line is not mandatory. Minimum separation of this line from the aircraft shall refer to Table 1-2.*

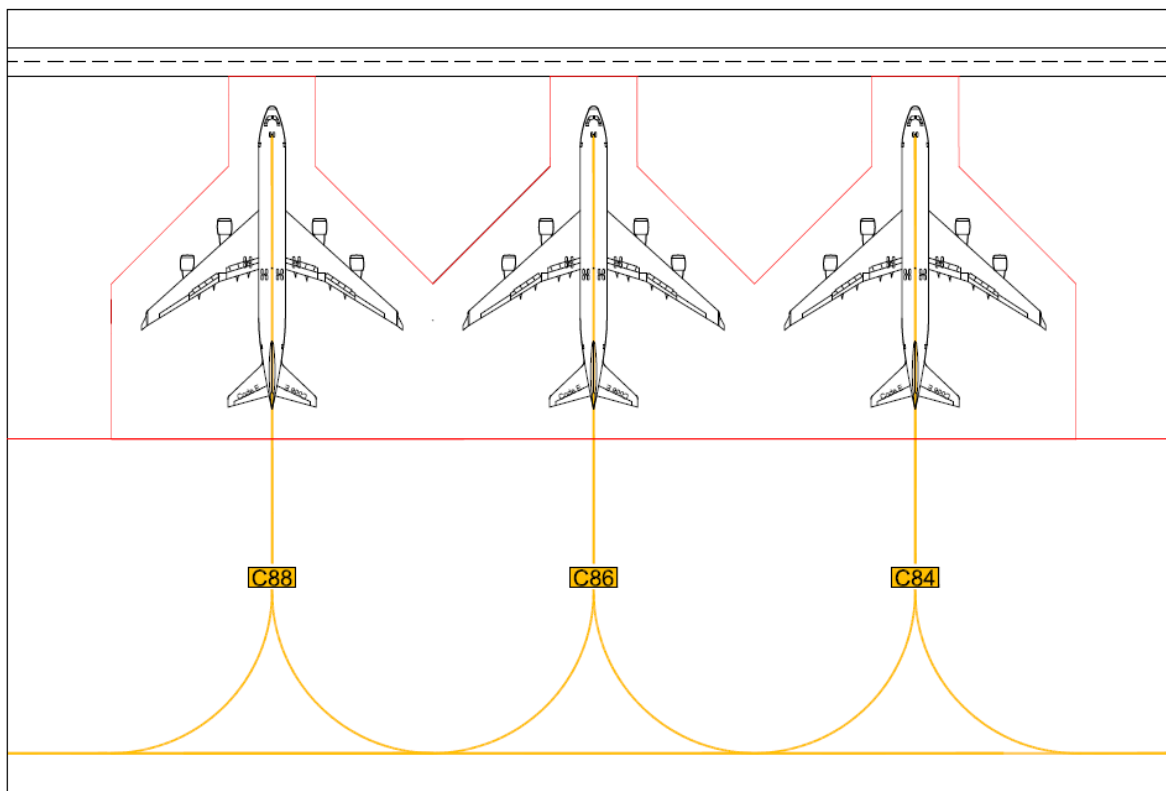

**Figure 16-1. Nose Tip Clearance Lines**



**INTENTIONALLY LEFT BLANK**

## 17 Wing Tip Clearance Lines

- 17.1 Purpose – This line depicts the area (at wing tips section) that must remain free of staff, vehicles and equipment when an aircraft is taxiing (or being towed) into position or has started engines in preparation for departure. Once all engine has been shut down and the anti-collision lights have been switched off, vehicles may cross the line to service the aircraft.
- 17.2 Characteristics – This line shall be continuous in length and at least 0.10 m in width. This line should be red in colour.
- 17.3 If the distance between wingtips of two adjacent aircrafts is less than 2 times of clearance distance as mentioned in Table 1-2 – Clearance Requirement, this line shall not be drawn.

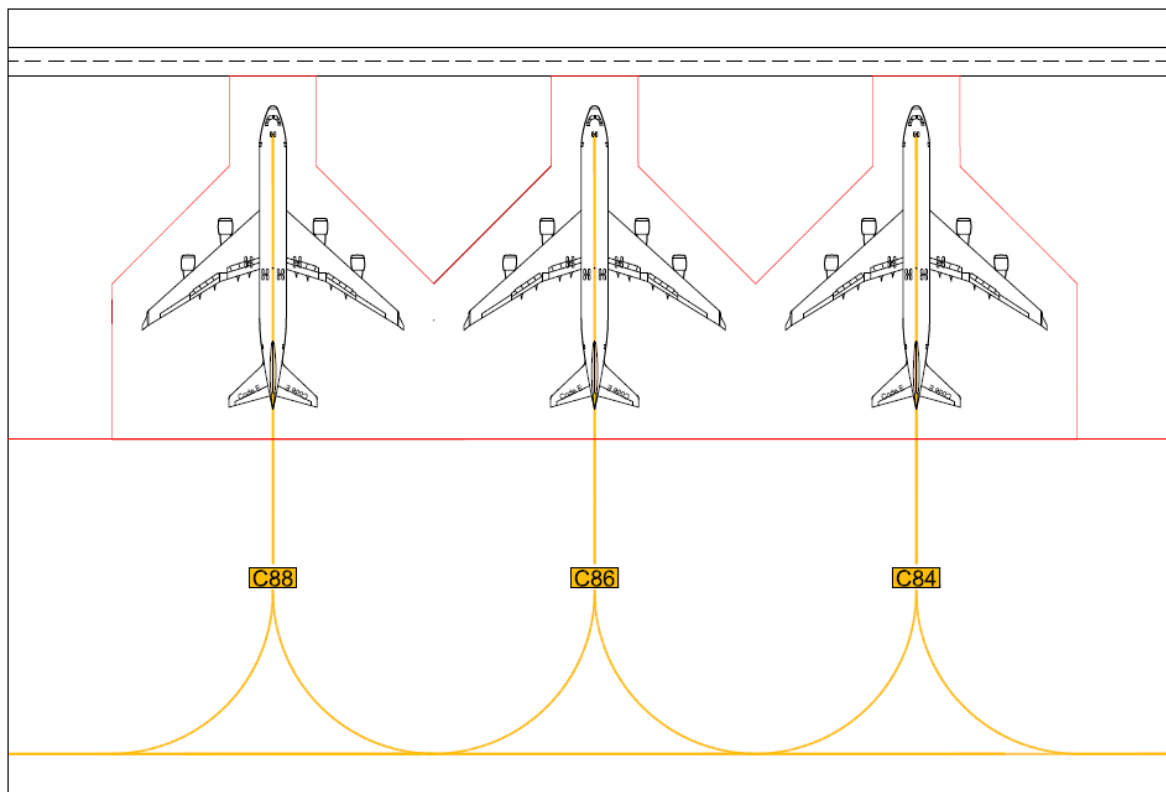

Figure 17-1. Wing tip clearance lines

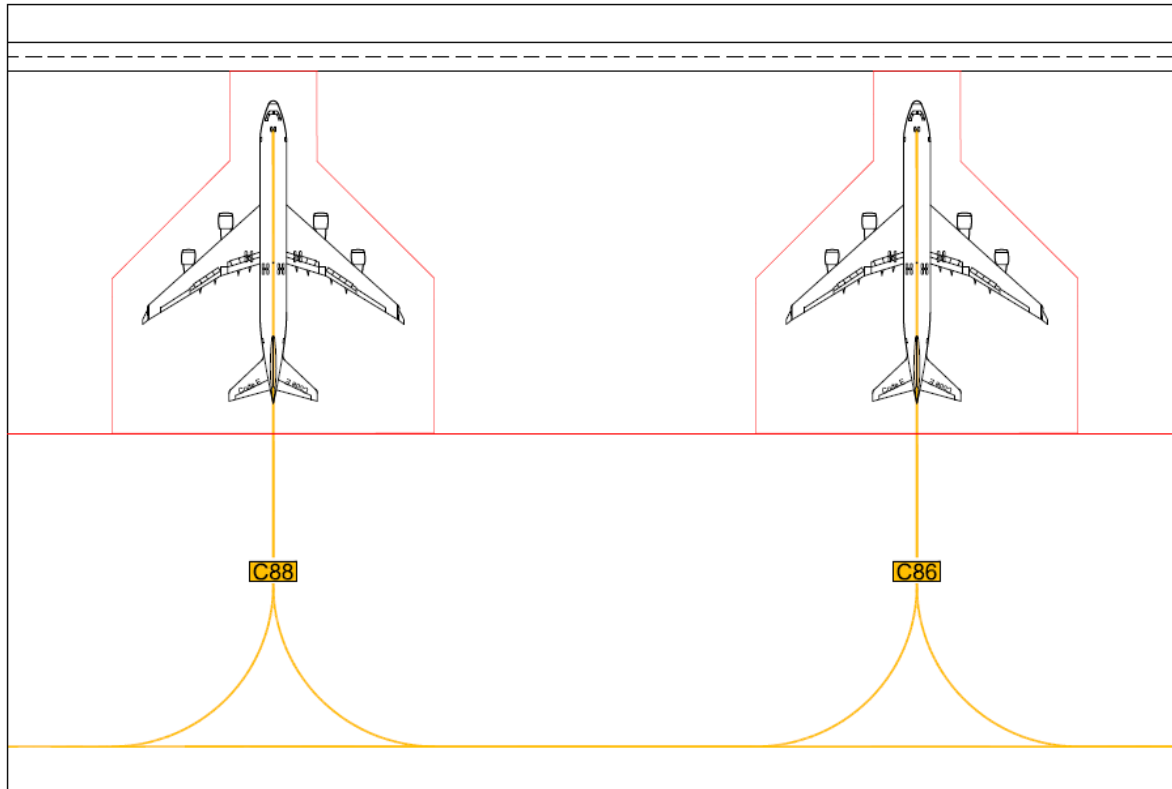
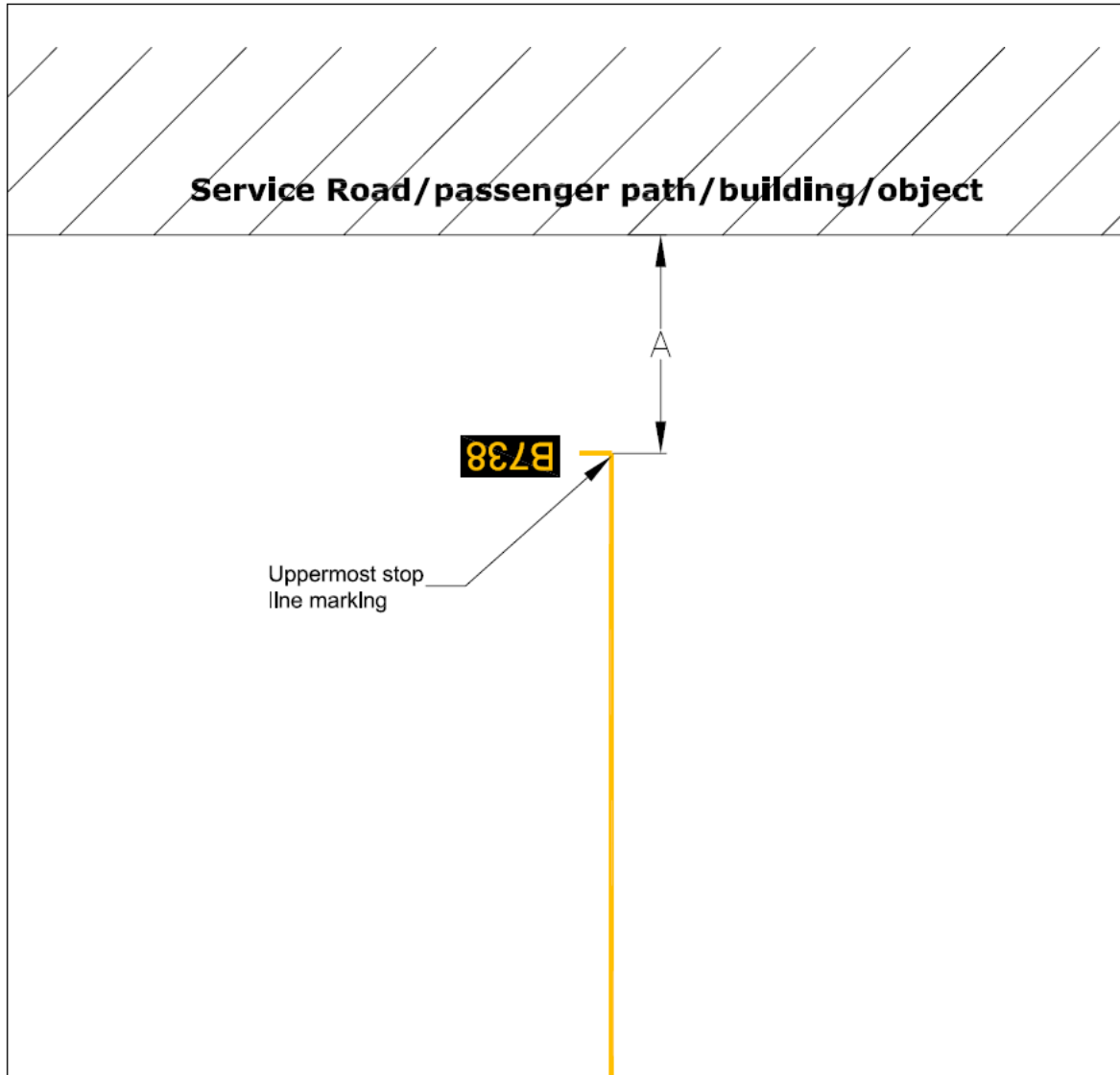

Figure 17-2. Wing tip clearance lines

## 18 Distance from Uppermost Stop Line Marking to The Service Road/ Passenger Path/ Building/ Object

18.1 Dimension A - Length 12 m (minimum)



**Figure 18-1. Distance from uppermost stop line marking to the Service Road/Passenger Path/Building/Object**

*Note. – For existing aircraft stand where there is space constraint, the minimum distance between building/service road to nose wheel position may be reduced subject to approval by CAAM Air Navigation Services & Aerodrome. However, if the said aircraft stand is upgraded, the requirement should be complied.*



**INTENTIONALLY LEFT BLANK**

## 19 Passenger Path Lines on Apron

19.1 Purpose – These lines are used to keep passenger, when walking on the apron, clear of hazards.

19.2 Colour: White

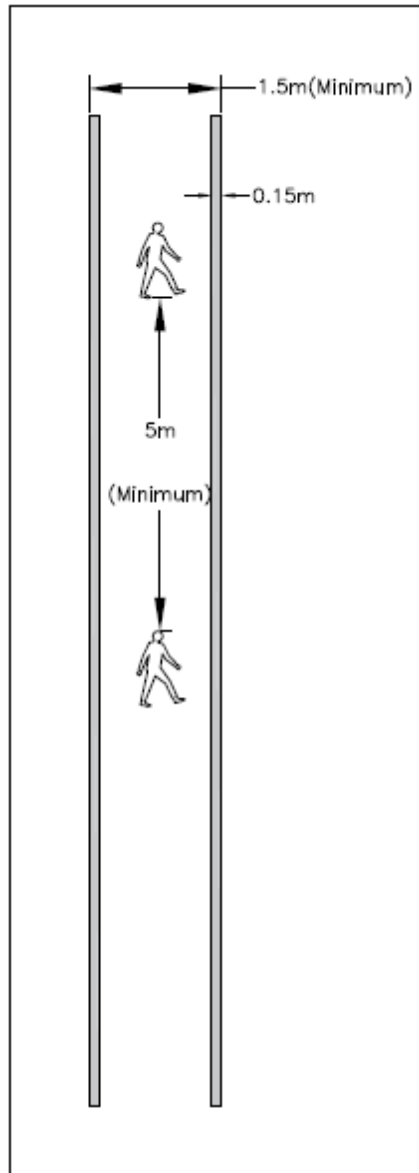

Figure 19-1. Passenger Path Lines



**INTENTIONALLY LEFT BLANK**



## 20 Taxiway/Aircraft Stand Taxilane Crossing Marking

20.1 Purpose – This marking is used where a service road crosses a taxiway or aircraft stand taxilane.

20.2 Dimension    A     1.0 m  
                       B     1.0 m  
                       C     0.1 m (minimum)

Colour            White

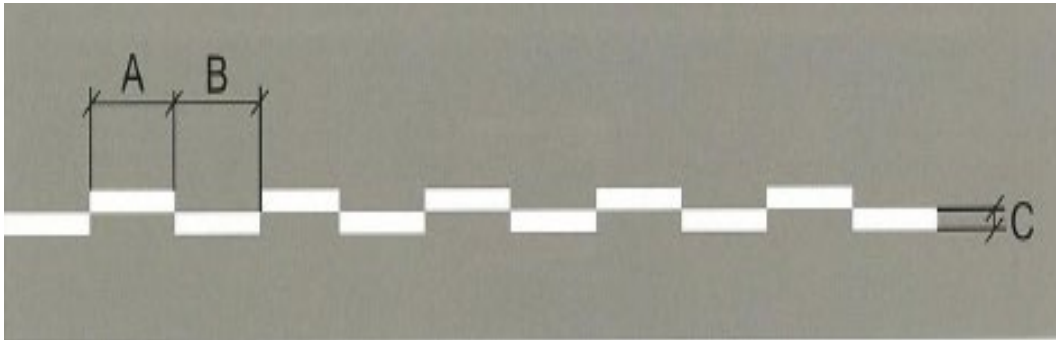

**Figure 20-1. Taxiway/Aircraft Stand Taxilane Crossing Marking**

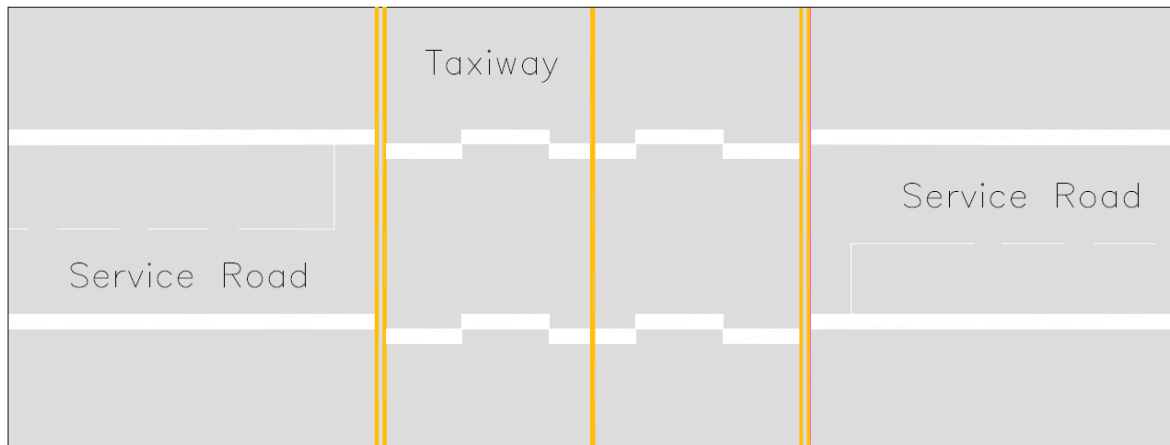

**Figure 20-2. Taxiway/Aircraft Stand Taxilane Crossing Marking**



**INTENTIONALLY LEFT BLANK**

## 21 General Requirements for Aircraft Stand Identification Signs

21.1 An aircraft stand identification sign shall be located so as to be clearly visible from the cockpit of an aircraft prior to entering the aircraft stand. Where there is space constraint, the sign can be excluded subject to approval by CAAM Air Navigation Services & Aerodrome.

21.2 An aircraft stand identification sign shall consist of an inscription in black on a yellow background.

21.3 Type of Signs:

- a) Hammerhead / PBB: should show bay number only
- b) VDGS: should show bay number and coordinates
- c) Remote stand: should show bay number and coordinates

*Note.* – For PIPO operations, the bay number and coordinates sign should be made available where feasible

21.4 The geographical coordinates of each aircraft stand sign shall be in degrees, minutes, seconds and hundredths of seconds.

### Dimension of Aircraft Stand Identification Signs

21.5 Bay number at hammerhead / PBB: Letter and number height should be 400 mm.

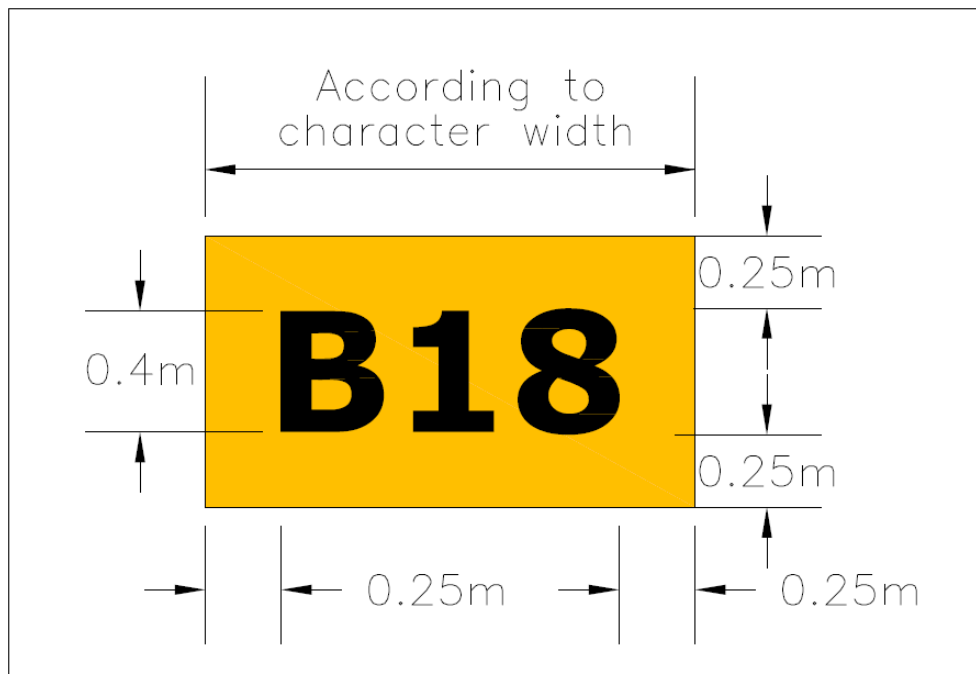
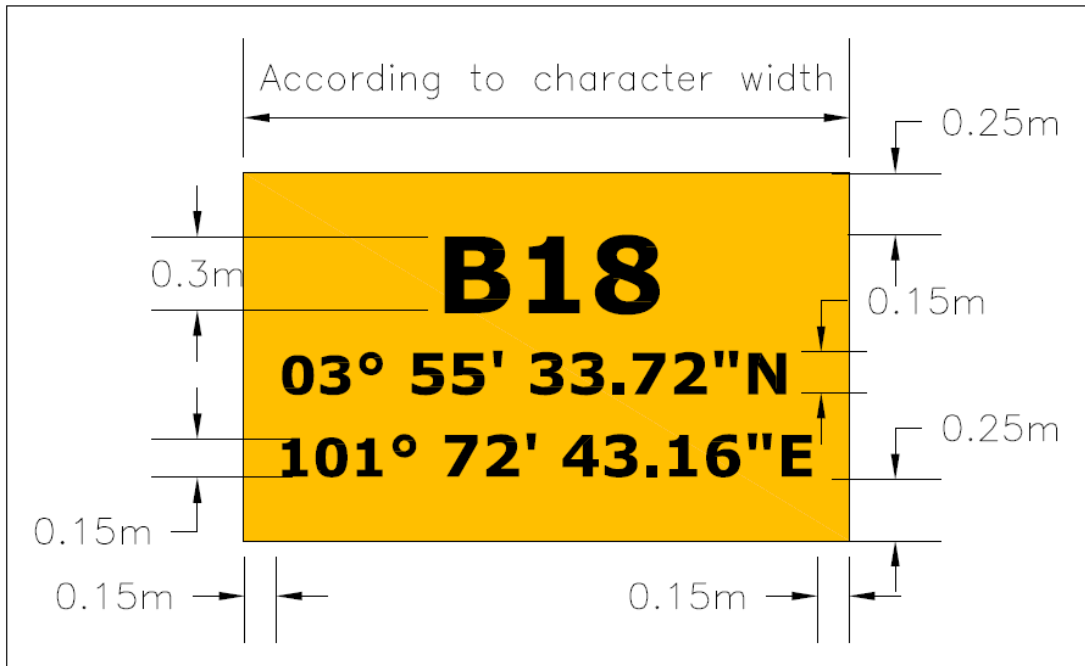

Figure 21-1. Bay Number at Hammerhead

- 21.6 Bay number and coordinates for VDGS and remote stand:  
 Letter and number height should be 300 mm  
 Coordinates height should be 150 mm



**Figure 21-2. Bay Number and coordinates for VDGS and remote stand**

- 21.7 Height of remote stand sign should be:
- Between 3.0 m to 4.6 m for aircraft code letter A, B, C or D
  - Between 6.0 m to 8.0 m for aircraft code letter E or F

*Note. – The height should be calculated based on pilot eye position height above ground for most demanding aircraft.*

- 21.8 The size of letters and numbers should be as follows:

**Table 21-1. Size of Letters and Numbers**

SPACE BETWEEN CHARACTERS		
Letter Height		
150 mm	300 mm	400 mm
Space		
10 mm	19 mm	26 mm

**Table 21-2. Letter and numeral widths and space between letters or numerals**

Letter	Width of letter		
	Letter height (mm)		
	150	300	400
	Width (mm)		
A	85	255	340
B	69	205	274
C	69	205	274
D	69	205	274
E	62	186	248
F	62	186	248
G	69	205	274
H	69	205	274
I	16	48	64
J	64	190	254
K	70	210	280
L	62	186	248
M	79	236	314
N	69	205	274
O	72	214	286
P	69	205	274
Q	72	214	286
R	69	205	274
S	69	205	274
T	62	186	248
U	69	205	274
V	76	229	304
W	89	267	356
X	69	205	274
Y	86	257	342
Z	69	205	274

**Table 21-3. Numeral Width**

Letter	Width of letter		
	Letter height (mm)		
	150	300	400
	Width (mm)		
1	25	74	98
2	69	205	274
3	69	205	274
4	75	224	298
5	69	205	274
6	69	205	274
7	69	205	274
8	69	205	274
9	69	205	274
0	72	214	286



**INTENTIONALLY LEFT BLANK**

## 22 Aircraft Type Designator

The aircraft type designators as listed below is not limited in the Table 22-1. For the detail update aircraft type designator please refer to ICAO Doc 8643 or ICAO's aircraft type designator page

(<https://www.icao.int/publications/doc8643/pages/search.aspx>)

22.1 Table below is the common aircraft type designator.

**Table 22-1. Aircraft Type Designator**

Manufacturer	Model	Designator (to be appeared on aircraft identification marking)
Airbus	A320	A320
Airbus	A320 NEO	A20N
Airbus	A321	A321
Airbus	A321 NEO	A21N
Airbus	A330-200	A332
Airbus	A330-300	A333
Airbus	A330-800	A338
Airbus	A330-900	A339
Airbus	A350-900	A359
Airbus	A350-1000	A35K
Airbus	A380-800	A388
ATR	ATR72-500	AT75
ATR	ATR72-600	AT76
DE HAVILLAND CANADA	DHC-6 (Twin otter)	DHC6
BOEING	B737-400	B734
BOEING	B737-800	B738
BOEING	B737-900	B739
BOEING	B737 MAX 7	B37M
BOEING	B737 MAX 8	B38M
BOEING	B737 MAX 9	B39M
BOEING	B747-400	B744
BOEING	B747-800	B748
BOEING	B777-200	B772
BOEING	B777-200ER	B772
BOEING	B777-200LR	B77L
BOEING	B777-300	B773
BOEING	B777-ER	B77W
BOEING	B787-8	B788
BOEING	B787-9	B789



**INTENTIONALLY LEFT BLANK**



## 23 Appendices

### 23.1 Appendix 1. Mandatory Instruction Markings and Information Markings

*Note.* – This appendix details the form and proportions of the letters, numbers and symbols of mandatory instruction markings and information markings on a 20 cm grid.

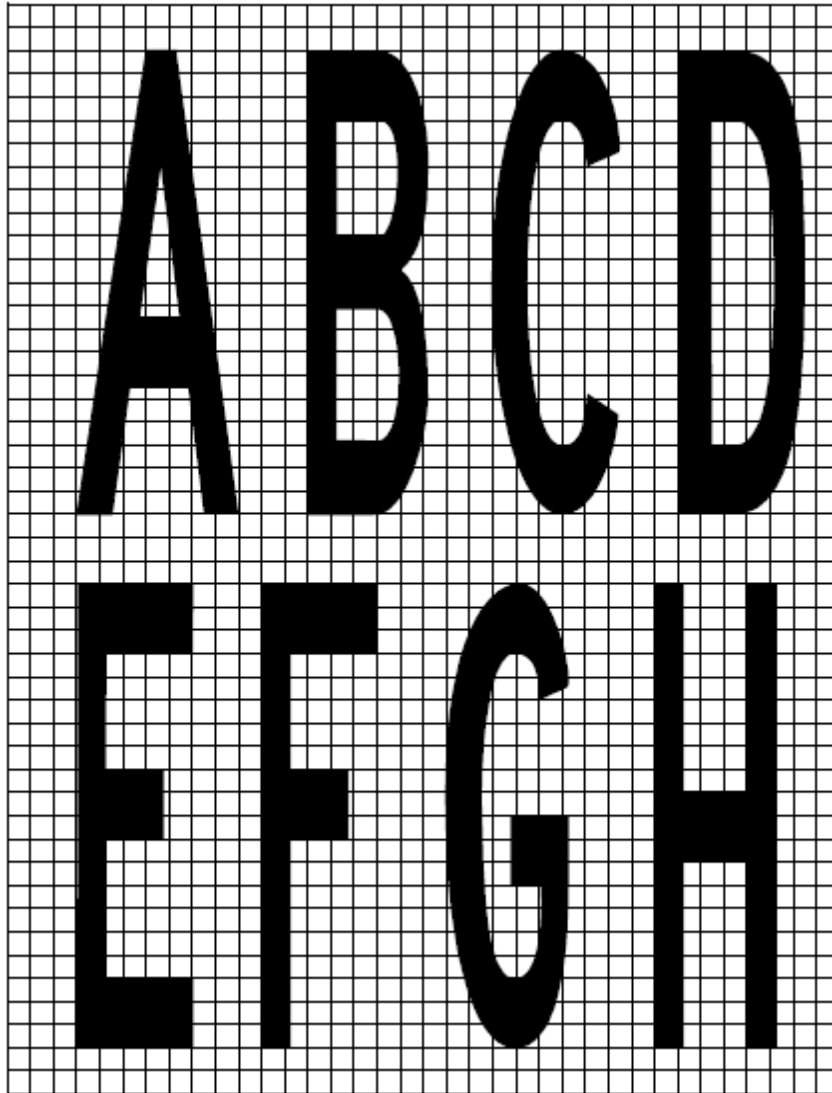

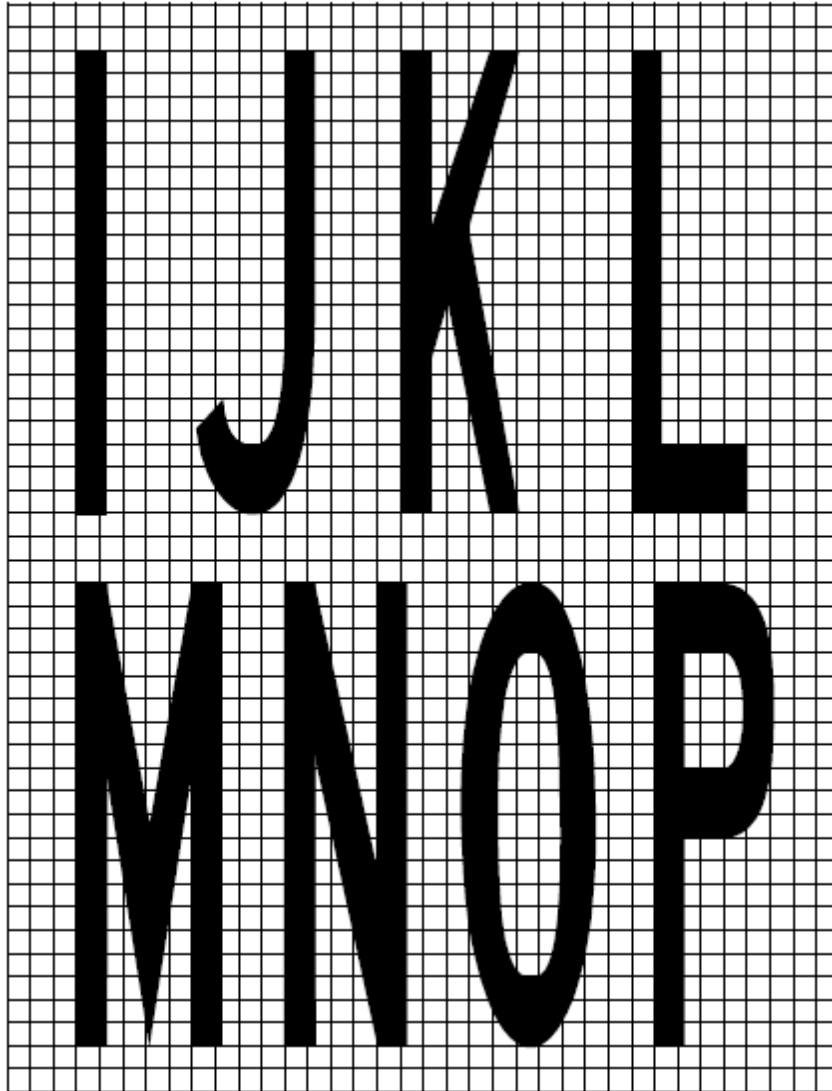

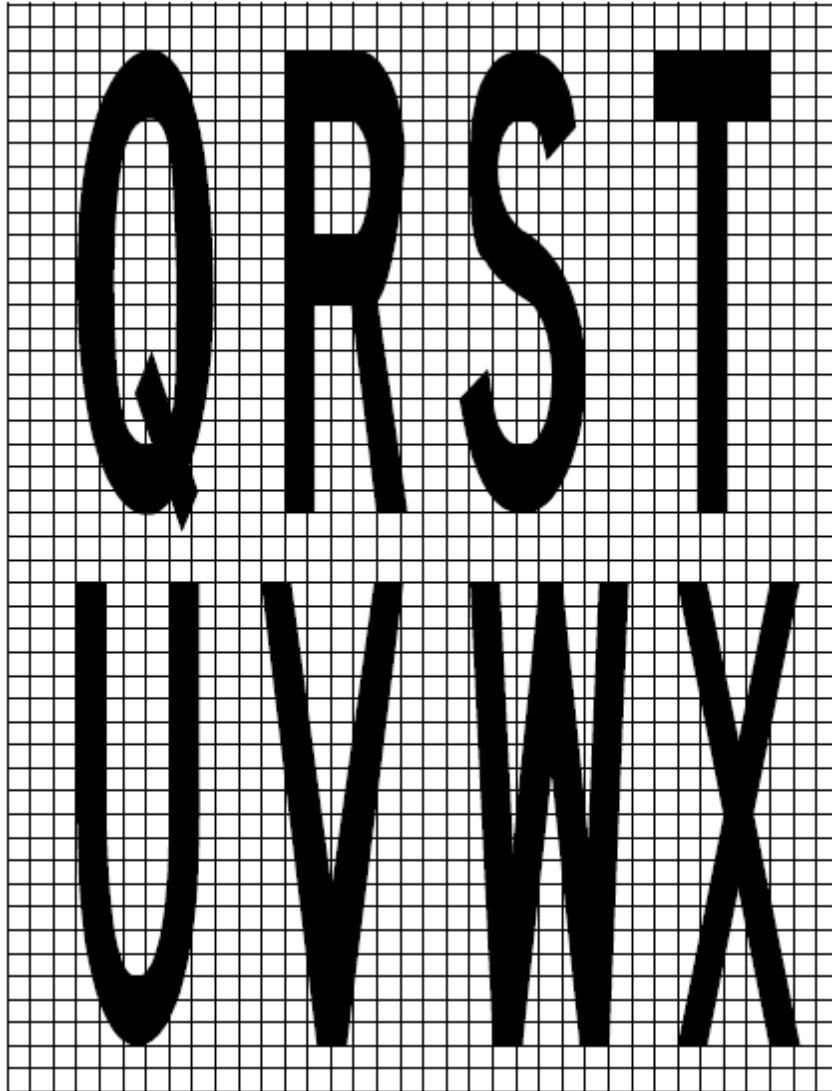

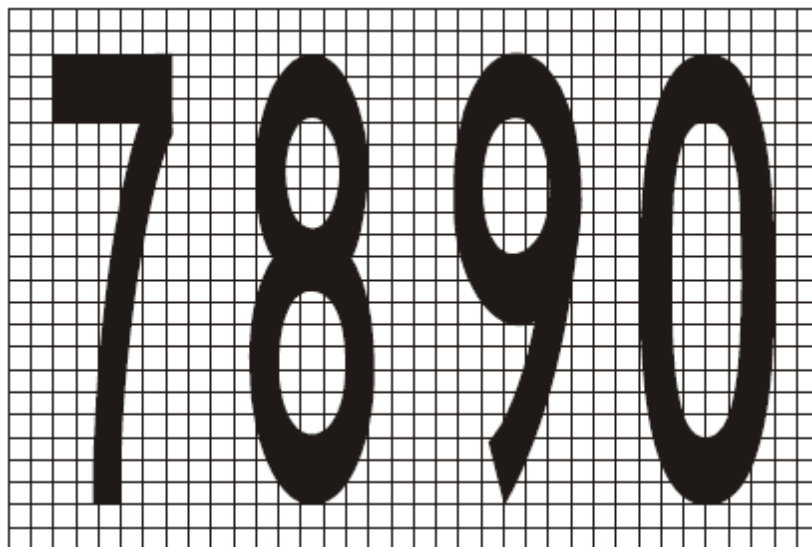
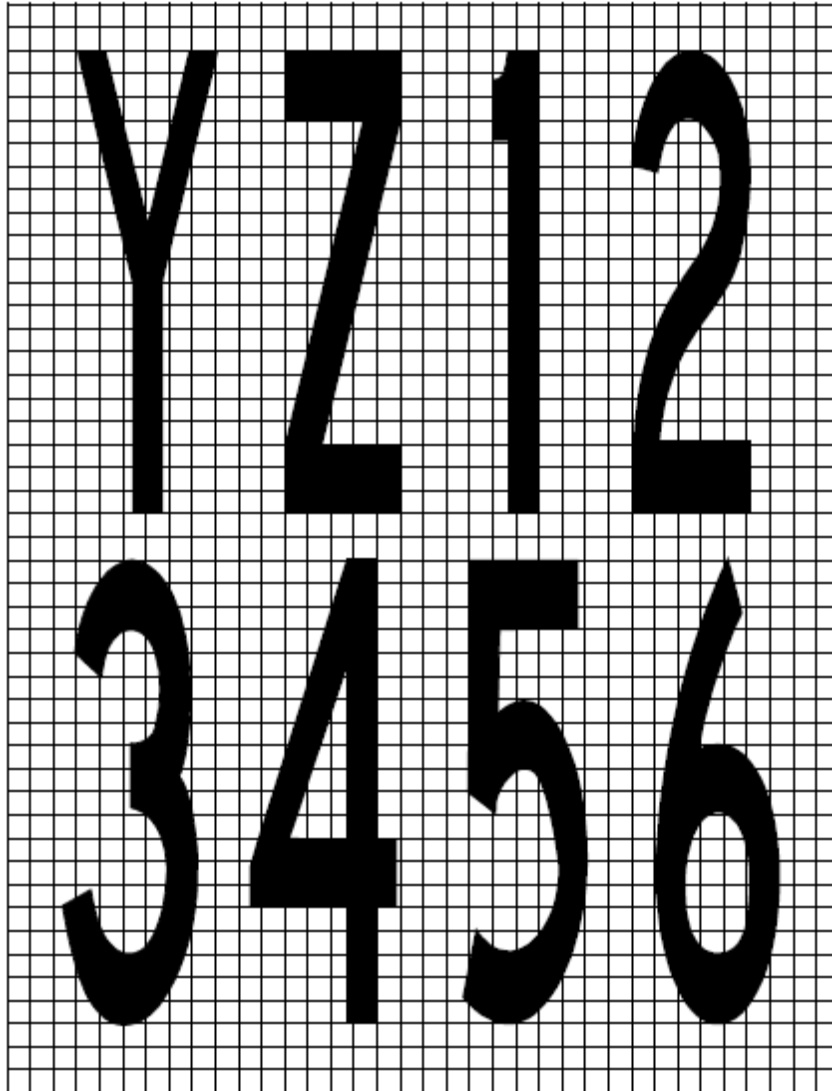

23.2 Appendix 2. Human Figure Dimension for Passenger Path Line

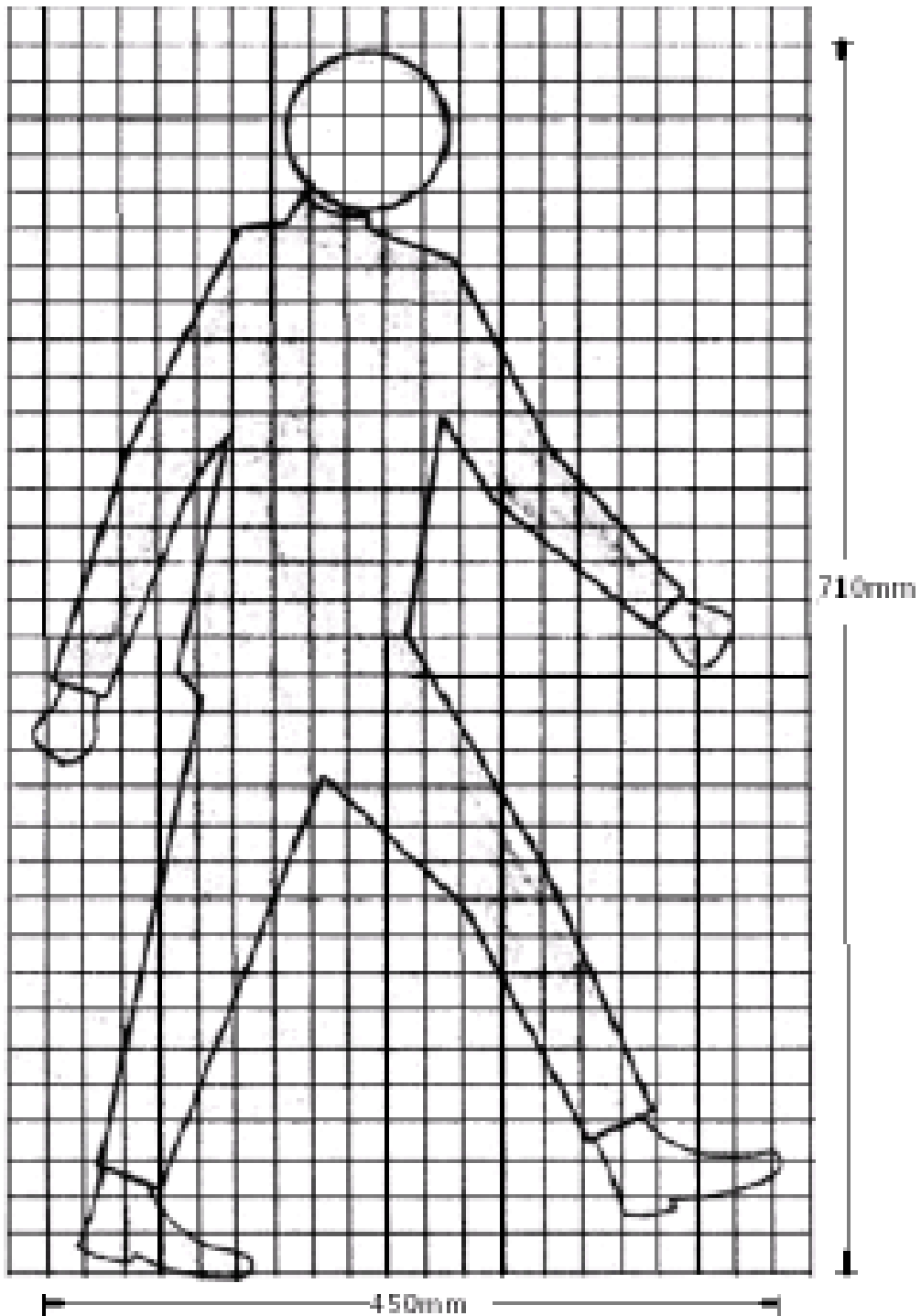



**INTENTIONALLY LEFT BLANK**